



**香港工程師學會**

**THE HONG KONG INSTITUTION OF ENGINEERS**

香港銅鑼灣記利佐治街1號金百利9字樓

9/F Island Beverley, No 1 Great George St, Causeway Bay, Hong Kong

電話Tel +852 2895 4446 傳真Fax +852 2577 7791

qandm@hkie.org.hk www.hkie.org.hk

## **The HKIE Structural Examination – Written Examination**

**Section 2: Design Questions  
(80% of the Written Examination)**

Date: 29 November 2013 (Friday)

Time: 12:00 nn - 06:00 pm

**Answer ONE question only**

## Question 1      Water Tower

### Client's Requirements (no figure)

1. A roofed water tower of 4,000 cu.m. capacity supported on a central support system bounded by a plan area not exceeding  $16\text{m}^2$ .
2. 4,000 cu. m. is to be stored in two separate compartments. Neither compartment is to be of less than 1,500 cu. m. capacity. The maximum area for the base of the water tank shall not be greater than  $250\text{m}^2$ .
3. Each compartment is to be usable while the other is emptied for maintenance.
4. The floor of the tower is to be 25m above ground level.
5. The compartments are to be vented to atmosphere (i.e. the water is not to be stored under pressure).
6. Maintenance access into the compartments is to be by manhole through the roof.
7. Because of the tower's prominence in the area an aesthetically pleasing shape and appearance is sought.

### Site Conditions

8. Open landscape in the North Western part of the New Territories, Hong Kong.
9. Ground conditions:-

0m – 5m	Field SPT N-value = 4
5m – 15m	Alluvium SPT N-value = 10
15m – 20m	CDG SPT N-value = 40
Below 20m	Granitic rock Grade III with 85% core recovering
Water table 1.5m below ground level	

### **Omit from Consideration**

- 10. Pipework and pipe penetrations.
- 11. Detailed design of access stairs.

### **Section A**

- a. Prepare a design appraisal with appropriate sketches indicating two distinct and viable schemes, for each of the superstructure and foundation, for the proposed water tower. Indicate clearly the functional framing, load transfer and stability aspects of the proposed structure of each scheme. Identify the scheme you recommend, giving reasons for your choice.

**(40 marks)**

### **Section B**

For the solution recommended in Section A:

- b. Prepare sufficient design calculations to establish the size and form of all principal elements including the foundation.
- c. Prepare general arrangement plans, sections and elevations to show the dimensions, layouts and disposition of the structural elements and critical details for estimation purposes.
- d. Prepare a detailed method statement for constructing the tower slabs and walls. Describe in detail the temporary works to be employed for the tower construction.

**(20 marks)**

**(25 marks)**

**(15 marks)**

## Question 2 Hotel Building

### Client's Requirements

1. A hotel building is to be constructed within the urban area of Hong Kong Island (see figure Q2).
2. The use of hotel building with the minimum headroom requirements and fire resistance rating is listed as follows:-

Floor Mark	Usage	Minimum Clear Headroom* (m)	Fire Resistance Rating
3/F – 10/F	Hotel guest rooms	2.5	1 hour
2/F	Plant rooms	2.5	
1/F	Ballroom	4.0	
G/F	Main lobby	4.2	
B1/F	Car park	2.5	4 hours
B2/F	Back of House	2.5	

\* The minimum clear headroom is the floor height clear of all structures and building services. A service zone of minimum 300mm depth should be allowed for underneath all floors.

3. The restrictions on the location of vertical structural elements are as follows:-
  - (i) Guest rooms (3/F to 10/F)
    - Only permitted along the periphery of the rooms
    - Not permitted inside the rooms and corridor
    - The minimum spacing for columns is 7.0m centres
  - (ii) Main lobby, Ballroom and Driveway (G/F & 1/F)
    - Only permitted along the periphery of the driveway, main lobby and ballroom
    - Not permitted inside the driveway, main lobby and ballroom
    - The minimum spacing for columns in these areas is 10.0m centres
  - (iii) Plant rooms (2/F), Car parking floor (B1/F) and Back of house (B2/F)
    - No restrictions

## **Imposed Loads**

4. The imposed loads should be in accordance with the Hong Kong Code of Practice for Dead and Imposed Loads 2011.

## **Wind Loads**

5. The wind loads shall be in accordance with the current Hong Kong wind code.

## **Site Conditions**

6. Abutting the southern boundary of the site is a 3-storey old brick wall building with shallow footing (see Section 1-1 of figure Q2).
7. Abutting the eastern and western boundary of the site is a 10-storey reinforced concrete building with pile foundation.

8. Ground Conditions:-

From +10.0mPD to -4.0mPD	: Loose Fill with SPT N-value < 10
From -4.0mPD to -14.0mPD	: Medium dense sand with SPT N-value 10-40
From -14.0mPD to -24.0mPD	: Dense sand with SPT N-value 30-50
From -24.0mPD to -30.0mPD	: Very dense sand with SPT N-value >100
Below -30.0mPD	: Slightly to moderately decomposed moderately strong rock of material weathering grade III or better, with total core recovery of more than 85%.

9. The highest possible groundwater level (H.P.G.W.L.) is at +10.0mPD and +4.5mPD respectively along southern boundary and northern boundary of the site.

## **Omit from Consideration**

10. Detailed layout and design of the structure inside the service and staircase cores.

## Section A

- a. Prepare a design appraisal and provide two distinct and viable solutions for the proposed superstructure with the aid of appropriate sketches. Indicate clearly the functional framing, load transfer path and stability aspects of each scheme. Identify the solution you recommend and give the reasons for your choice. (20 marks)
- b. Based on the superstructure solution you recommend, prepare an overall stability check for the whole building and propose measures, if necessary, to fulfill stability requirements in accordance with the Code of Practice for Foundations. (12 marks)
- c. Propose a viable foundation for the building and set out the design considerations for the foundation design for the recommended structural scheme. (8 marks)

## Section B

For the solution recommended in Section A:-

- d. Prepare design calculations to establish the form and size of all the principal structural elements for the superstructure at guest room floor, 3/F, 2/F and B2/F. (14 marks)
- e. Prepare dimensioned framing plans for guest room floor, 3/F, 2/F and B2/F. (20 marks)
- f. Prepare structural details for the principal structural elements at guest room floor, 3/F, 2/F and B2/F for cost estimation purposes. (14 marks)
- g. Provide a viable pile wall system together with the method of installation for the excavation for the basement. Give reasons for your choice. (4 marks)
- h. Propose measures to mitigate the adverse effects of basement excavation on the adjoining buildings. (4 marks)
- i. Prepare an outline construction programme from commencement of the construction to the completion of building. (4 marks)

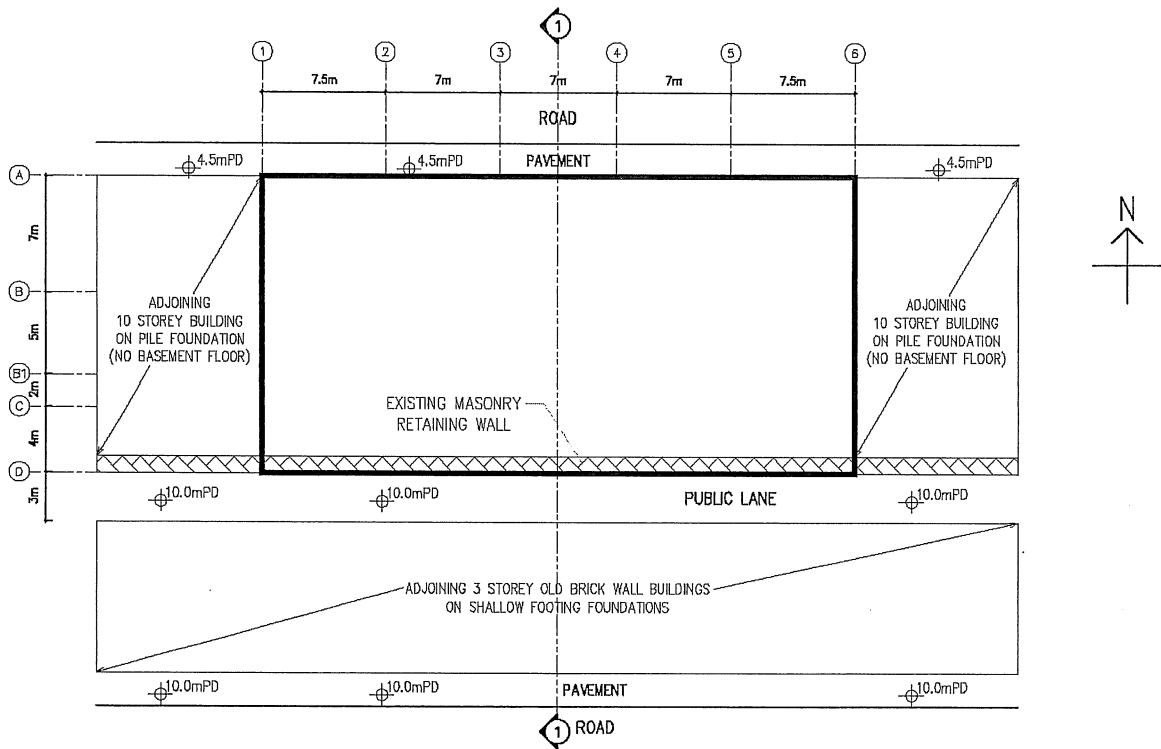

**Q.2.-EXISTING GROUND PROFILE**

LEGEND:

EXISTING MASONRY RETAINING WALL

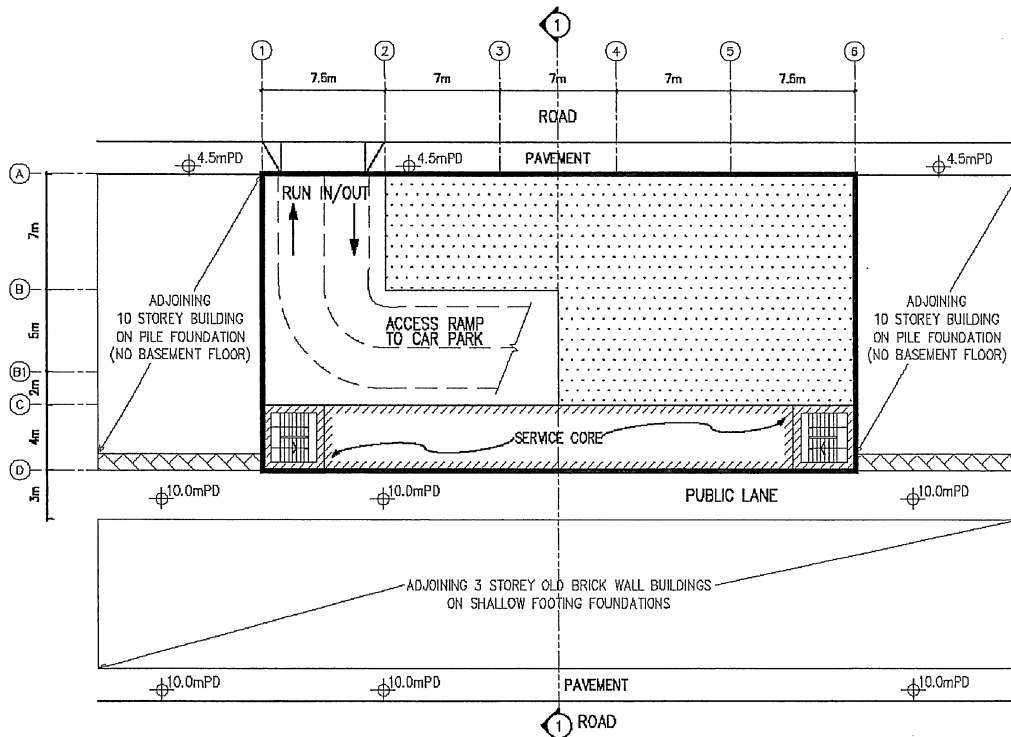

**Q.2.-G/F FLOOR PLAN**

LEGEND:

MAIN LOBBY

Figure Q2

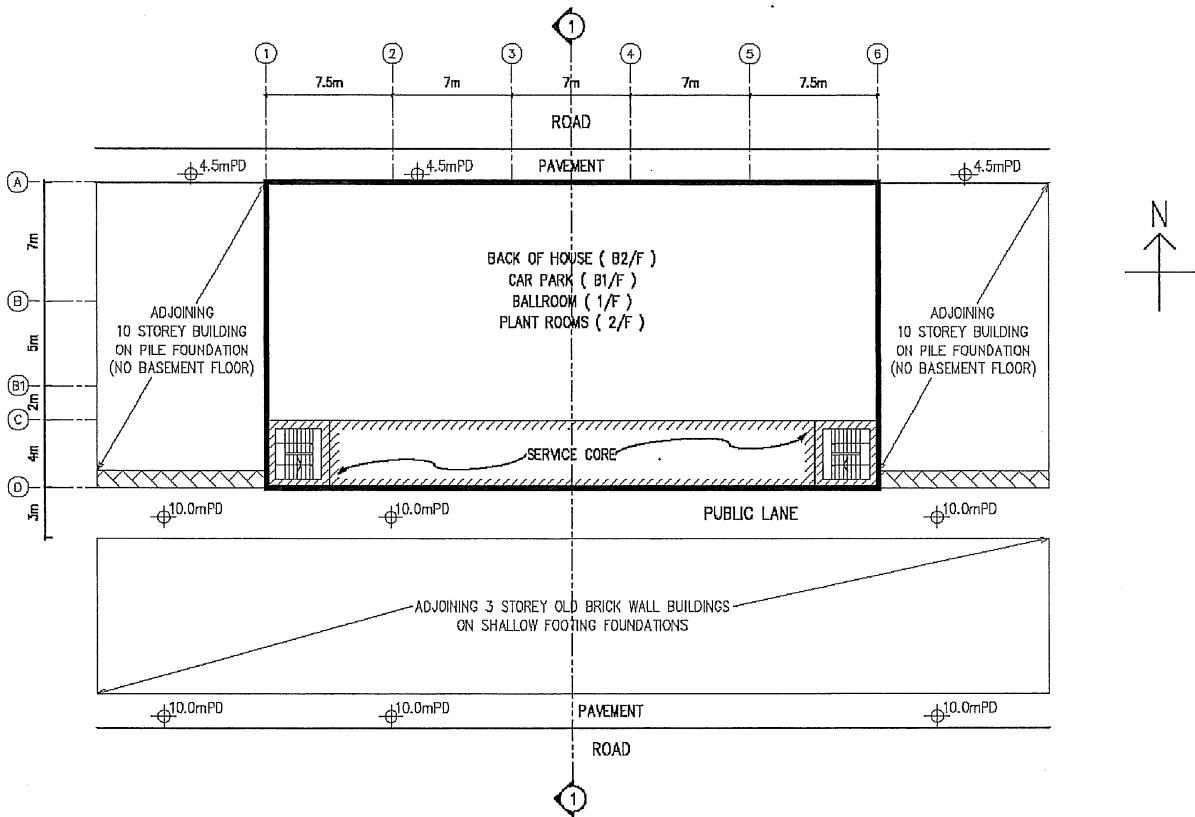

Q.2.-B2/F, B1/F, 1/F & 2/F FLOOR PLAN

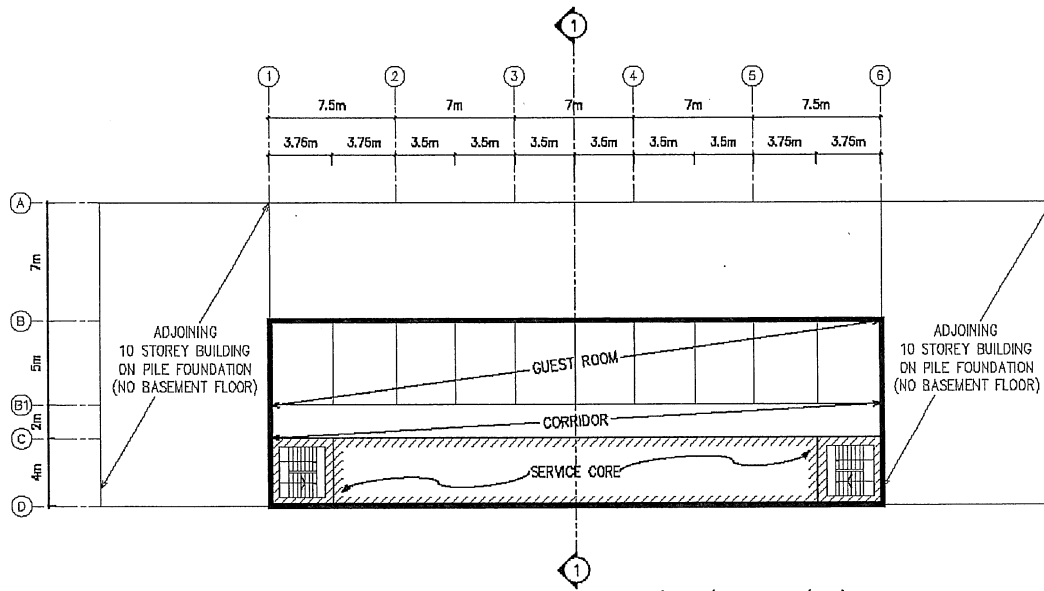

Q.2.-TYPICAL FLOOR PLAN ( 3/F - R/F )

Figure Q2

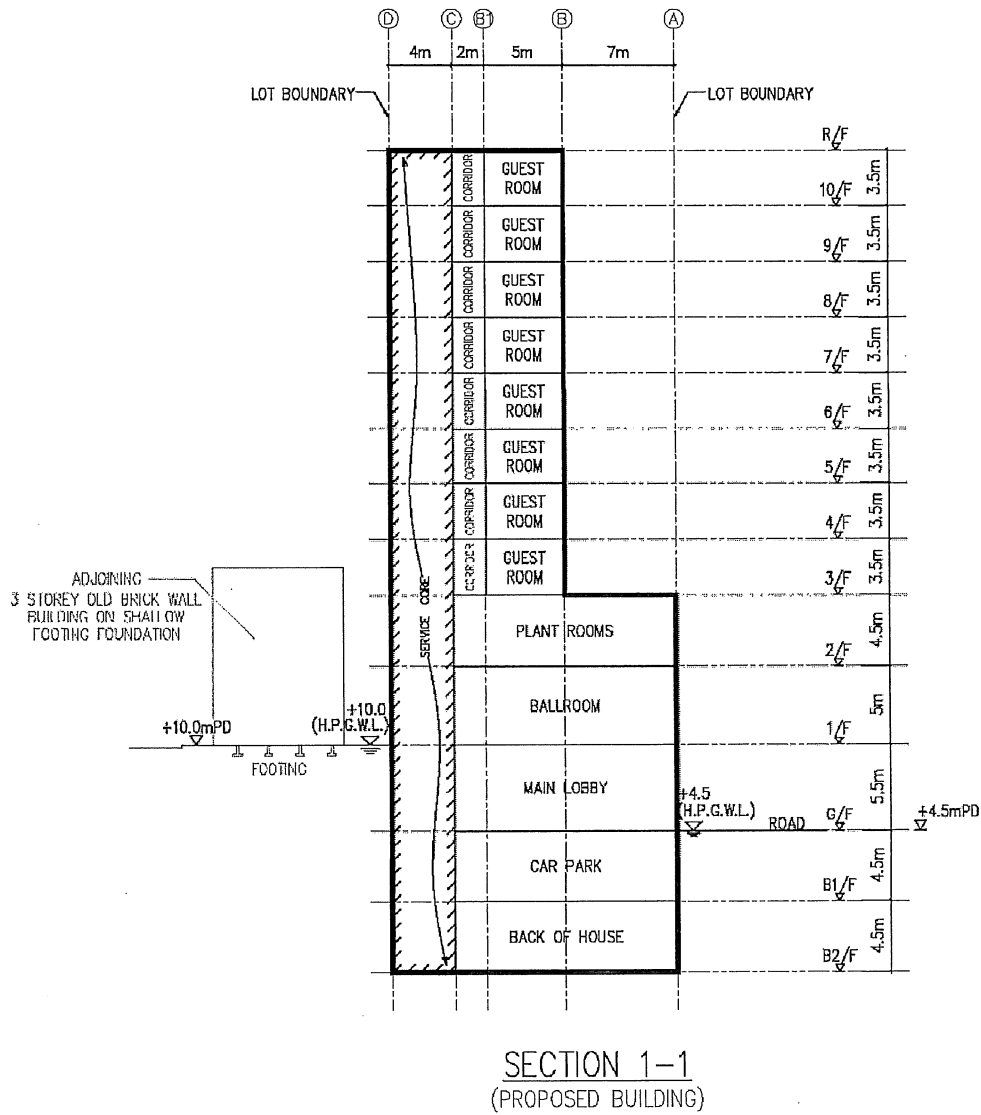
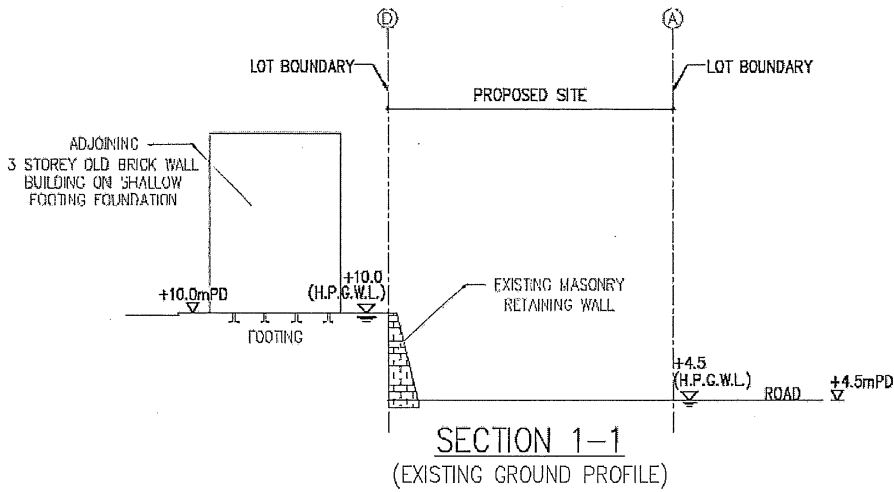

Figure Q2

## Question 3 Office Tower over Freight Yard

### Client's Requirement

1. An 8-storey office is to be constructed over a part of a freight yard with a tower footprint of 108m x 102m.
2. The lateral dimension of the rails is 40m. A railway protection zone of 3m on each side of the rail is required (see figure Q3a).
3. No columns/walls are permitted in between the rails or in the protection zone. Columns must be set back 3m from the perimeters of the building.
4. For better office layout, a column grid in the multiples of 1.5m should be provided with a minimum column spacing of 10.5m.
5. Four stair wells are required to be provided for access.
6. The ground floor is located at 5mPD. The building has an overall height restriction of 60mPD (see figure Q3b).
7. The freight yard must remain operational between 5:00am to 11:00pm every day. It can be closed from 11:00pm to 5:00am if required, subject to special application to the Rail Authority.
8. The floor to floor between the ground and the first floor is 10m, while that between the office floors is 4.5m.
9. A clear floor to ceiling height for the ground and office floor is 6.5m and 2.8m respectively.
10. The following should be allowed in the design of the building:

<u>Floor</u>	<u>Finishes</u>	<u>Building Services Zone</u>
- Ground	Nil (Existing)	1.2m
- Office	150mm raised floor	0.6m
11. The plants will be located at the roof which is non-accessible.

## Imposed Loads

12. The imposed loadings should be in accordance with the Hong Kong Code of Practice for Dead and Imposed Loads 2011.
13. The wind load should be in accordance with the current Hong Kong wind code.

## Site Conditions

14. The generalized ground conditions are :

Depth	Stratum		SPT N-value
Ground level to 15m	Fill		10 to 15
15m to 20m	Alluvial sand		15 to 20
20m to 40m	Completely Decomposed Granite (CDG)		30 to 200
40m to 50m	Completely Decomposed Granite (CDG) / Highly Decomposed Granite (HDG)		≥ 200
≥ 50m	Slightly to moderately decomposed moderately strong rock of material weathering grade III, with a total core recovery of more than 85% of the grade.		

The groundwater table is encountered at 2.5m below ground.

## **Section A**

- a. Prepare a design appraisal with appropriate sketches including two distinct and viable solutions for the proposed tower including two viable foundation systems. Indicate clearly the functional framing, load transfer and stability aspects of each scheme. Identify the solution you recommend and give reasons for your choice. **(30 marks)**
- b. Explain how the building structure will resist wind load with design assumptions. **(10 marks)**

## **Section B**

For the solution recommended in Section A:

- c. Prepare sufficient design calculations to establish the form and size of all the principal structural elements including the foundations. **(20 marks)**
- d. Prepare general detailed structural framing plans to show the dimensions, arrangements of the structural elements and details of the critical structural elements for estimating purposes. **(20 marks)**
- e. Prepare sufficient details of the critical connections such as column splices, beam splices, column/beam and beam/slab connections, etc. **(10 marks)**
- f. Prepare a detailed method statement for the safe construction of the building including any measures for the protection of the freight yard during construction. **(10 marks)**

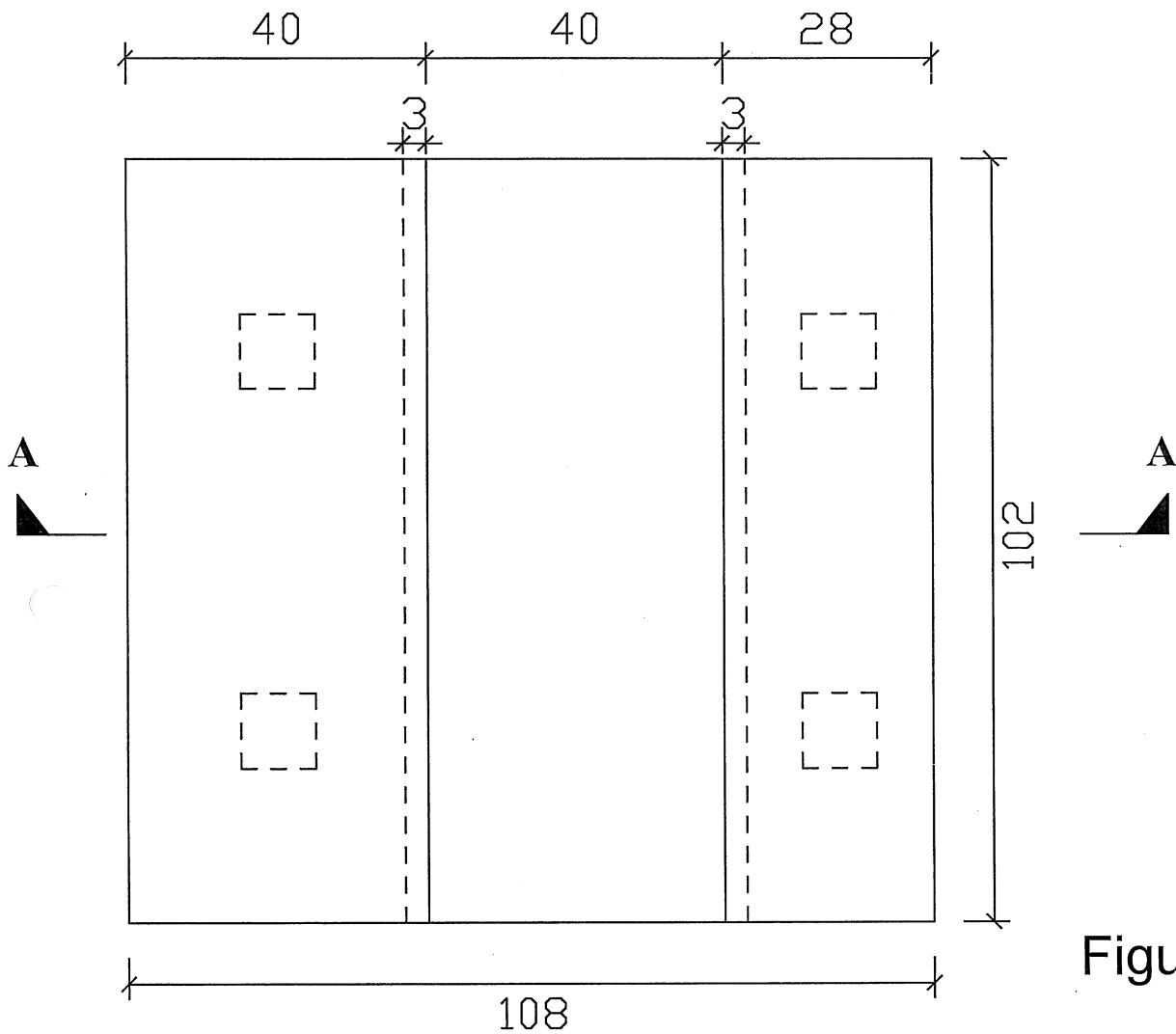
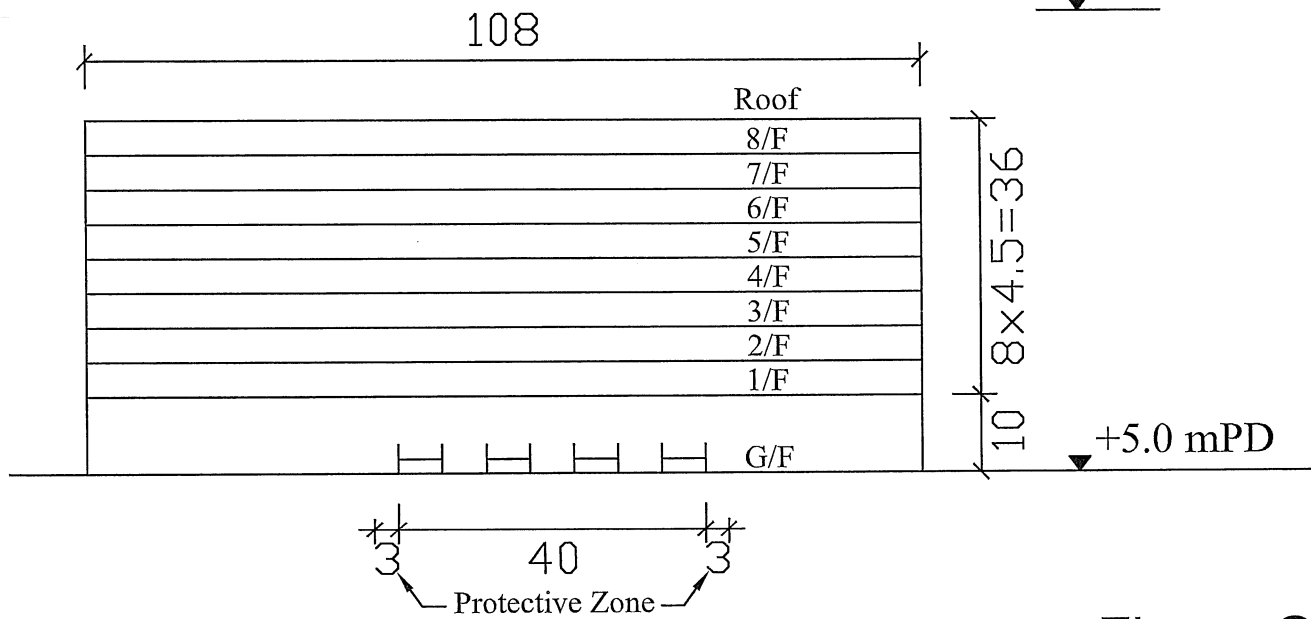

Figure Q3a

**PLAN** Note: All Dimensions Are in Metres

+60.0 mPD Height Limit



**Section A-A** Note: All Dimensions Are in Metres

Figure Q3b

## Question 4      A Steel Industrial Building

### Client's Requirements

1. A new 3-storey industrial building is proposed as shown in figure Q4.
2. The on plan dimensions of the building are 150m by 50m. The minimum clear height of the ground floor is 13.8m. The minimum clear height for each upper floor is 4.2m. There is an overall height limit of 26m.
3. For speed and ease of construction, the client requires the building to be constructed in structural steel.
4. The roof and sides of the building should be cladded in metal cladding.
5. An underground box culvert (4m wide by 4m deep) crosses the site. The top of the box culvert is 2.5m from the ground surface. The culvert shall be protected at all stages of construction.
6. A column free zone 90m by 20m is to be provided on the ground floor. No columns are allowed in the column free zone on the ground floor.
7. The top of the foundations should be at least 2m below the ground surface. This is to allow the laying of utility services within the site.
8. A minimum 2-hour fire resistance rating is required for all elements of construction.

### Imposed Loads

9. Roof	2 kN/m <sup>2</sup>
Second floor	7.5 kN/m <sup>2</sup>
First floor	7.5 kN/m <sup>2</sup>
Ground floor	10 kN/m <sup>2</sup>

### Site Conditions

10. The site is flat and is located near the sea front. Design wind pressure shall follow current Hong Kong wind code.

## Ground Conditions

11. Ground conditions as revealed by drill holes are

From ground level to 5m – very loose and compressible Fill, N values range from 2 to 4.

From 5m to 8m – Alluvium, medium dense silty Sands, N values range from 12 to 20.

From 8m to 12m – Soft marine clay, N values range from 2 to 4.

From 12m to 30m – Completely Decomposed Tuff – dense to very dense Silty Sands, N values range from 50 to 180.

From 30m onwards – Moderately Decomposed Tuff, total core recovery greater than 85%.

## Section A

- a. Prepare a design study with appropriate sketches and calculations indicating two distinct and viable schemes for the proposed structure including one scheme for the foundations.

**(40 marks)**

## Section B

For the solution recommended in Section A:

- b. Prepare sufficient calculations to establish the size of all the principal structural elements including the foundation.

**(25 marks)**

- c. Prepare framing plans, sections and elevations to show the dimensions, layout and disposition of the structural elements and critical details for estimating purposes.

**(25 marks)**

- d. Prepare a simple method statement and programme for the safe construction of the structure.

**(10 marks)**

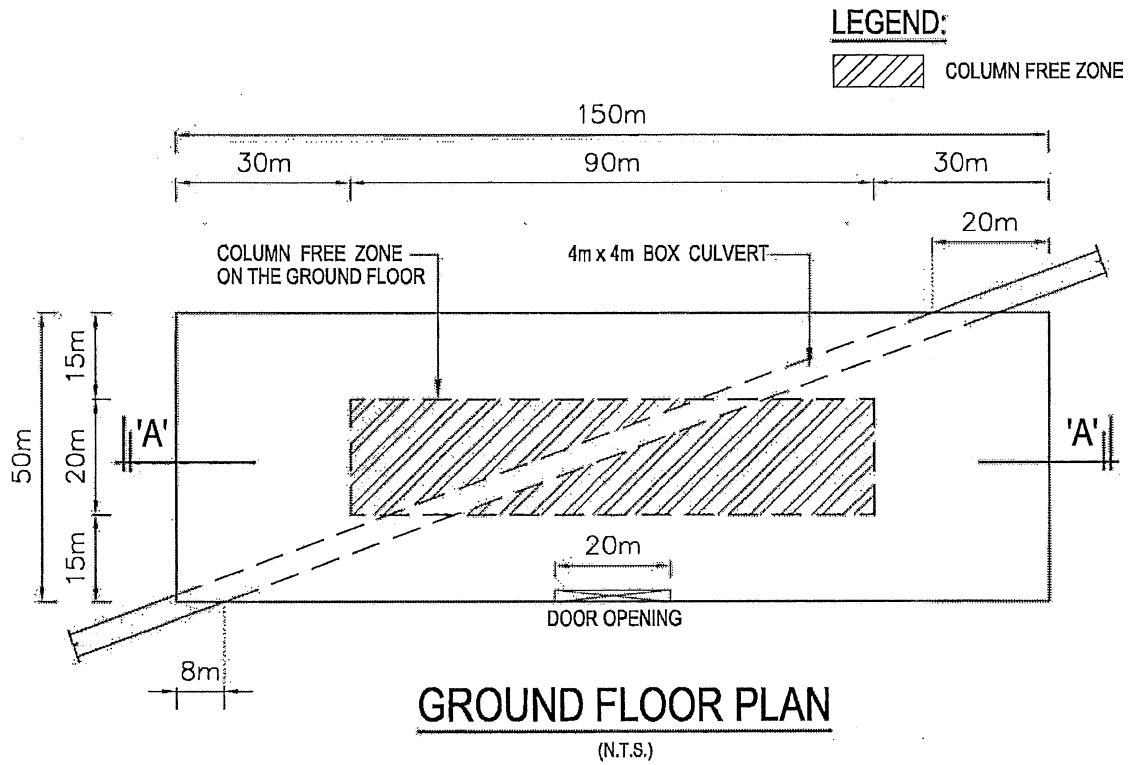

BUILDING HEIGHT LIMIT 26m FROM THE GROUND LEVEL

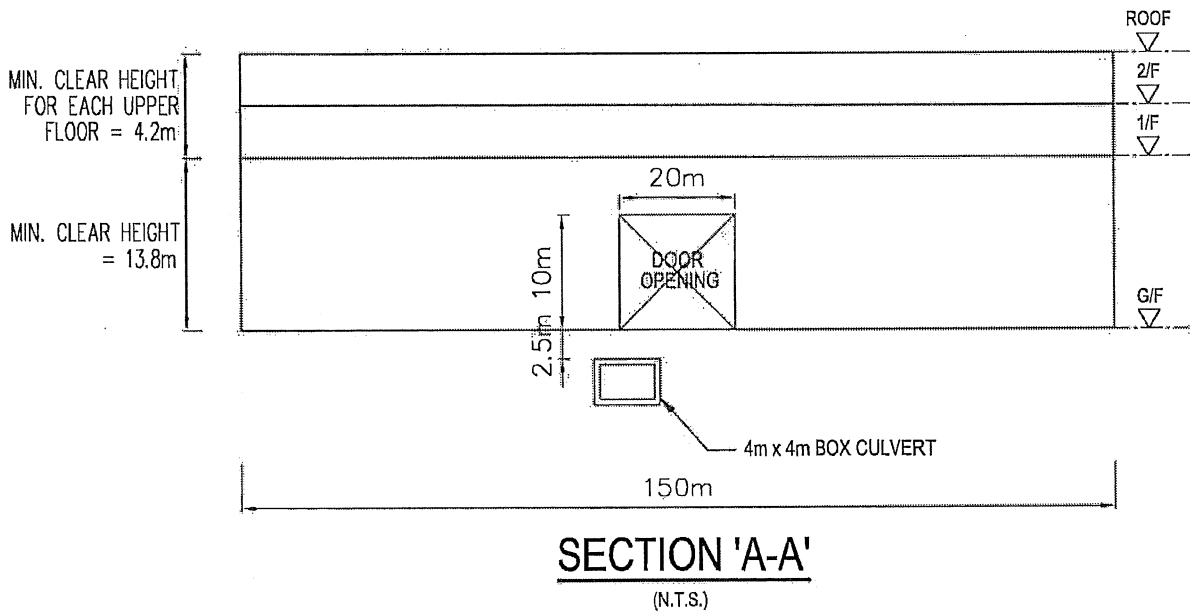

Figure Q4

## Question 5      School Project

### Client's Requirements

1. A 7-storey school is to be constructed in urban area of Kowloon (see figure Q5).
2. Due to budget purpose, it is intended to construct the school into two phases as indicated in figure Q5. Phase 2 extension will be built later.
3. Subject to the lease condition, no part of the structure can be built above +32.5mPD.
4. Main entrance, staff office and sport hall are located on G/F, staff office on 1/F and classrooms are located on 2/F to 6/F.
5. Classroom size is 6m x 6m with a feasibility to merge two classrooms (room 1 and 2, room 3 and 4) into one room with minimum clear headroom of 3.6m.
6. No columns / walls are permitted within the classrooms and sport/community hall.
7. Minimum width of the corridor on classroom floors is 3m.
8. Minimum requirements on clear headroom (clear height of all structure, finishes and building services) are as follows:

<u>Floor / Location</u>	<u>Min. Headroom (m)</u>	<u>Finishes and Services Zone (m)</u>
Ground floor		
-Sport/Community hall	6.0	0.5
-Entrance/Corridor/Office	3.3	0.1
1/F Staff office	3.3	0.1
2/F to 6/F		
-Classroom	3.6	0.1
-Corridor	3.3	0.1

9. A minimum 2-hour fire resistance rating is required for all elements of construction.

## Imposed Loads

10. The imposed loads shall be in accordance with the Hong Kong Code of Practice for Dead and Imposed Loads 2011.
11. Design wind pressure shall follow current Hong Kong wind code.

## Site Conditions

12. The site is located in urban area of Kowloon at a datum level of about +4.5 mPD.
13. Ground conditions are:

Ground level – 2m	Fill, SPT N-value = 10
2m – 20m	CDG, SPT N-value = 100
20m – 40m	HDG with SPT N-value varies from 150 to 200

Ground water is encountered at 2m below ground.

## Omit from Consideration

14. Detailed layout and design of the structure inside the stair.

## Section A

- a. Prepare a design appraisal with appropriate sketches including two distinct and viable solutions for the proposed school project including two viable foundation systems. Indicate clearly the functional framing, load transfer and stability aspects of each scheme to meet all client's requirements. Identify the solution you recommend and give reasons for your choice.

**(30 marks)**

- b. Explain how the building structure will resist wind load including detailed description of the structural wind loads and design assumption. Prepare a detailed wind load calculation for the proposed school with the consideration of the further extension and demonstrate the wind load to be used for the proposed phase 1 development.

**(10 marks)**

## **Section B**

For the solution recommended in Section A:

- c. Prepare sufficient design calculations to establish the form and size of all the principal structural elements including the foundation system.  
**(20 marks)**
  
- d. Prepare general detailed structural framing plans to show the dimensions, arrangements of the structural elements and details of all critical structural elements for estimating purposes.  
**(20 marks)**
  
- e. Prepare a detailed method statement for the safe construction of the building including the sport/community hall and foundation works.  
**(10 marks)**
  
- f. Prepare a detailed construction programme from commencement of foundation to completion of structural works.  
**(10 marks)**

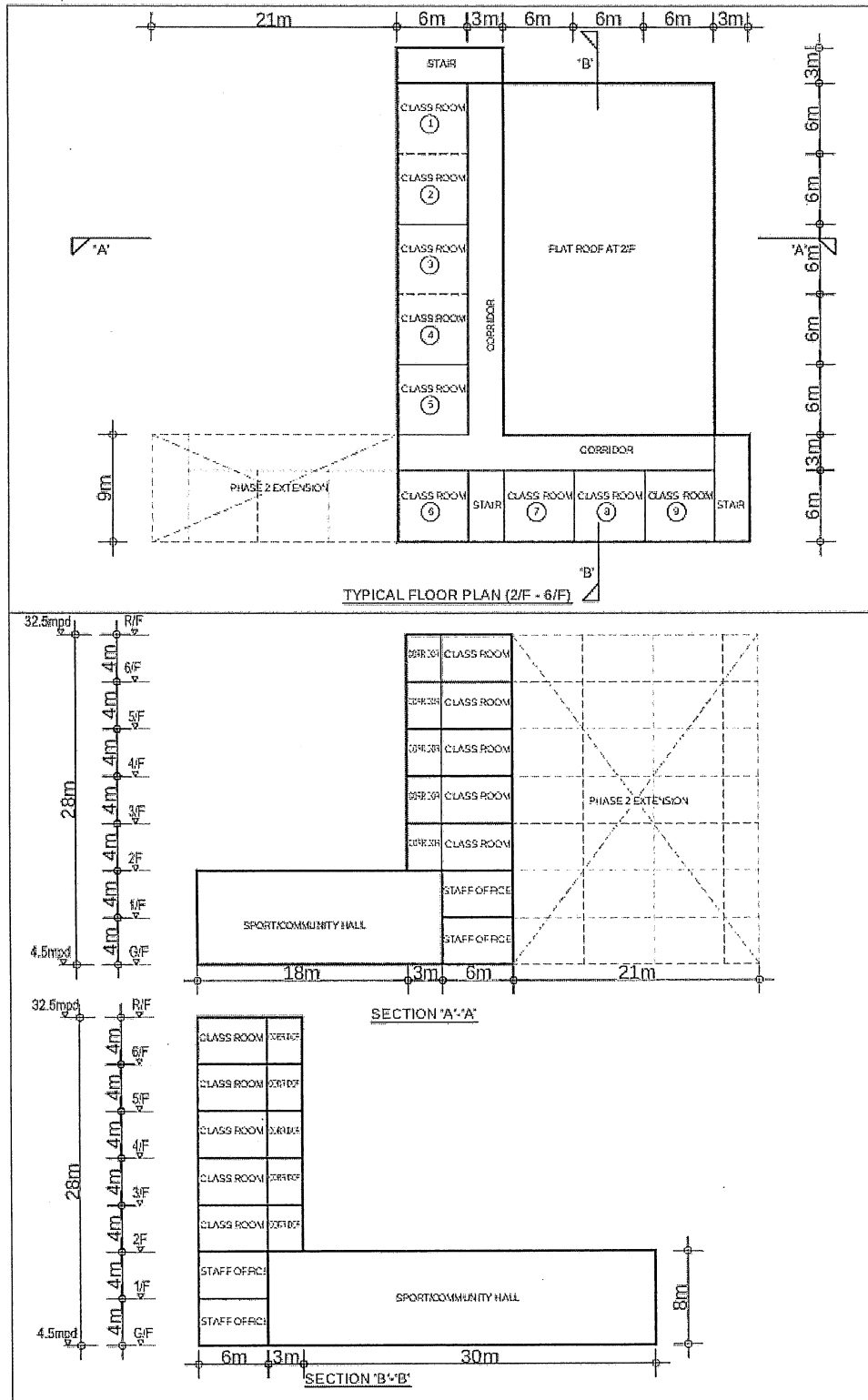

Figure Q5

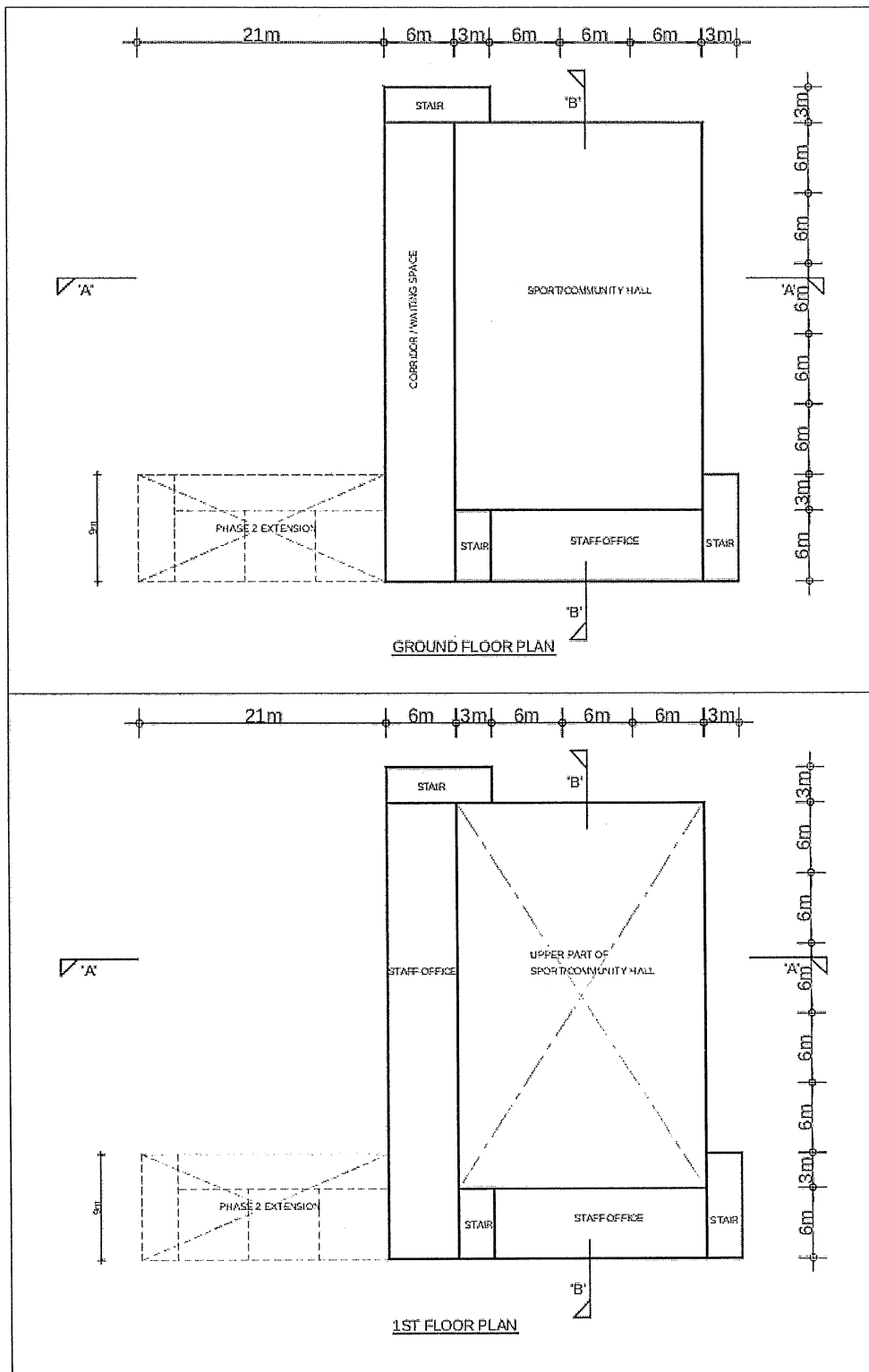

Figure Q5

## Question 6 Road Bridge over Rivers

### Client's Requirements

1. A new bridge carrying a dual two-lane carriageway with cycle track and footpath at one side is to be constructed over 2 rivers in country side (see figure Q6).
2. For navigation purpose, no bridge columns and footings are permitted inside the rivers.
3. Navigation envelopes of 20mx4.5m and 10mx3m have to be maintained at all times for the two rivers respectively as shown in figure Q6. However temporary works are allowed outside the two navigation envelopes during construction.
4. The river traffic must remain in operation at all times except from 1:00am to 5:00am for a period of not more than 6 months by special application to the relevant authorities to facilitate bridge construction. Deck or bridge parapet construction work may only be carried out above the navigation envelopes during their closure periods. Both rivers have constant width as shown in figure Q6.
5. The longitudinal gradient of the new bridge deck shall not be steeper than 1:100. Vehicular parapets are to be provided. A lateral clearance of 5m must be provided between the face of the column and river bank.
6. A staircase of 6m overall width linking the footpath on the bridge and the ground of the Botanic Garden for the visitors will be constructed two years later as shown in figure Q6. The staircase is structurally independent of the Road Bridge but necessary jointing provision shall be considered in the detailing of the bridge structure.

### Imposed Loads

7. Vertical traffic loads	UDL = 10.0 kN/m <sup>2</sup> Invariable KEL = 120 kN per traffic lane
Horizontal traffic loads	1500 kN, applied parallel to the carriageway across the full width of the bridge deck
Footpath load	5.0 kN/m <sup>2</sup>
Cycle track	5.0 kN/m <sup>2</sup>

### Site Conditions

8. Wind loads in accordance with the current Hong Kong Structures Design Manual for Highways and Railways.
9. The site is in the rural area.
10. Ground conditions as revealed by boreholes are:

Ground level – 0.8m	Made up ground
0.8m -12.0m	Soft clay with undrained shear strength, $C_u = 40.0 \text{ kN/m}^2$
Below 12.0m	Moderately decomposed rock with allowable bearing pressure = $3,000 \text{ kN/m}^2$

Ground water was encountered at 0.8m below ground level.

### Omit from Consideration

11. Design calculations for bridge parapet and the bridge abutment at the Eastern end.

### Section A

- a. Prepare a design appraisal with appropriate sketches indicating two distinct and viable schemes for each of the proposed bridge structure over the two rivers. The functioning framing, load transfer, safety and stability aspects of your schemes must be clearly indicated. Identify the solution you recommend, giving reasons for your choice.

**(40 marks)**

## **Section B**

For the solution recommended in Section A:

- b. Prepare sufficient design calculations to establish the form and size of all main components including foundations. **(25 marks)**
  
- c. Prepare general arrangement drawings including sufficient plans, elevations, sections, etc. for the bridge structure for quantity taking off purposes. **(20 marks)**
  
- d. Prepare a simple method statement and programme for the safe construction of the bridge. **(15 marks)**

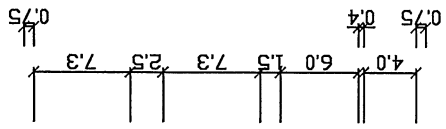
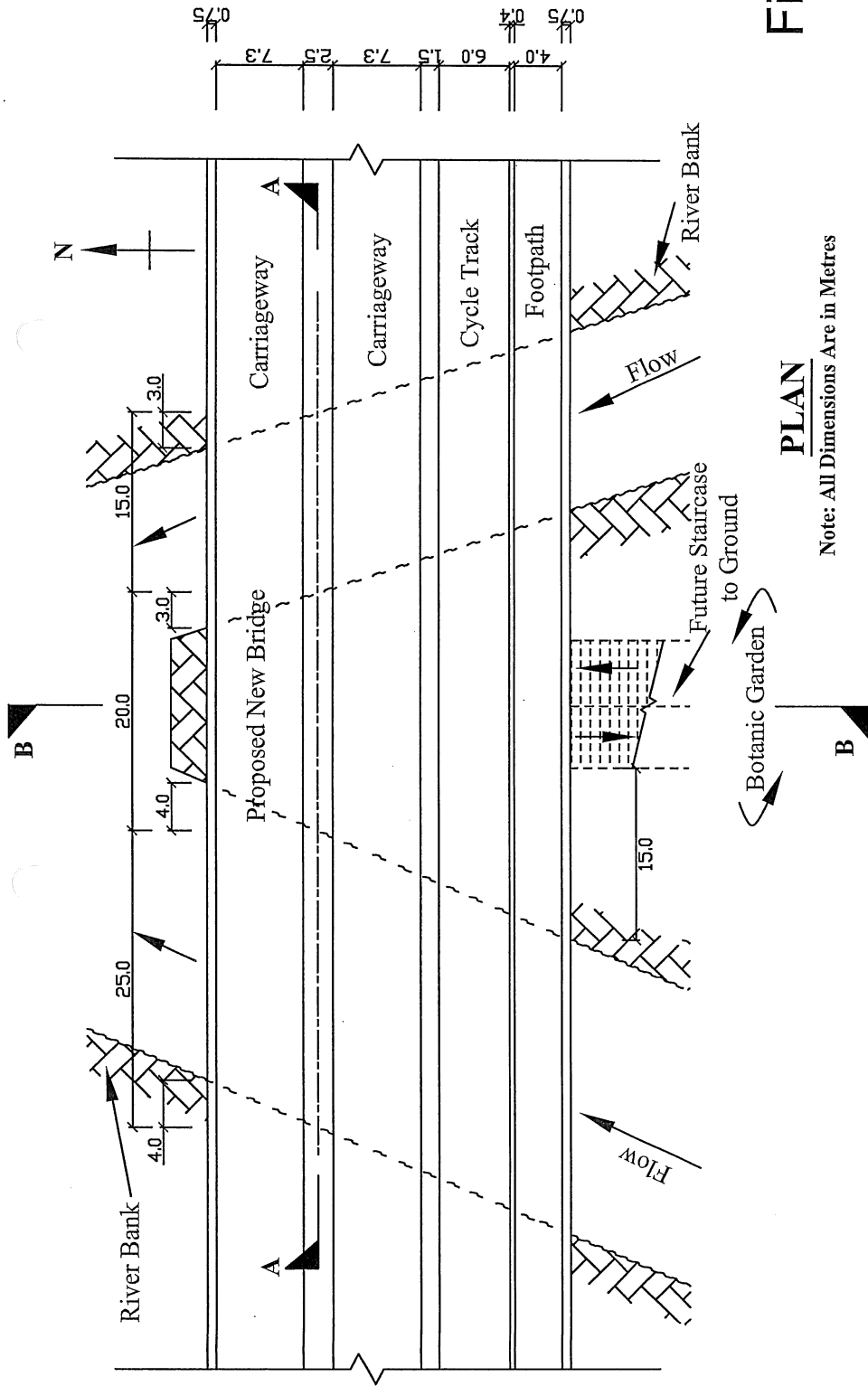

**Figure Q6**

**PLAN**

Note: All Dimensions Are in Metres

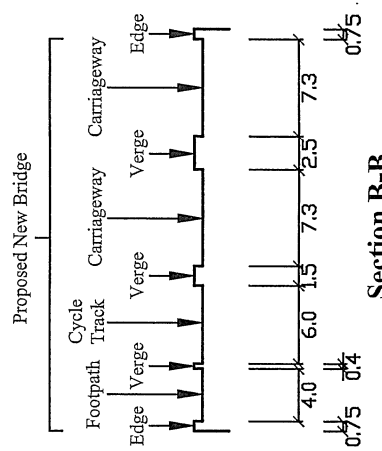

**Section B-B**

Note: All Dimensions Are in Metres

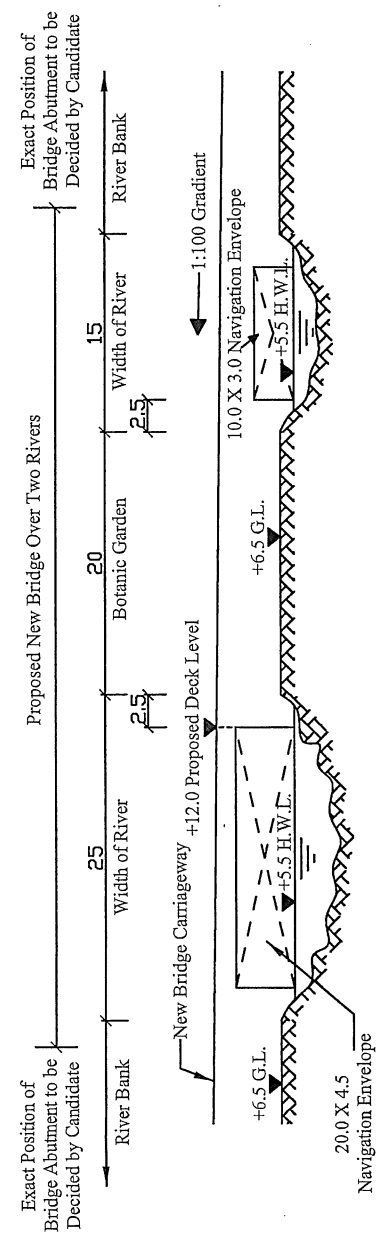

**Section A-A**

Note: All Dimensions Are in Metres