

The HKIE Structural Examination – Written Examination 2022

Section 2: Design Questions

Date: 21 November 2022 (Monday)

Time: 12:15 pm – 6:15 pm

(Duration: 6 hours)

Question Paper

Seat number:	
--------------	--

Answer ONE question only

Question 1 Data Centre over Vehicular Tunnel

Client's Requirements

The following client's requirements must be met:

1. A ten-storey data centre is to be constructed over a twin vehicular tunnel with a building footprint of 55m x 84m. See Figure Q1a.
2. A single level of basement is to be provided for loading/unloading area, plant rooms and carparks. A ramp to basement, with an opening of 12m x 20m on ground floor, is located at the eastern boundary of the building.
3. The overall width of the tunnel is 22m. A protection zone of 3m is required around the tunnel. See Figure Q1b.
4. No structures are permitted in the protection zone, and any changes in stresses in any directions to the tunnel should be limited to 20kPa.
5. For data equipment, a clear column spacing (between inner face of columns) shall be in the multiples of 1.2m with a minimum column spacing of 12m, except a column free space is required between the cores in the E-W direction with a clear span of 28.80m for the flexibility to accommodate more advanced equipment in the future for data floors 1/F to 5/F inclusive.
6. Four lift/stair wells, with an internal dimension of 5m x 9.6m with opening facing the data floor, are required to be provided for access at the perimeter of the building, which should also be used for the provisions of all supporting utilities/facilities, in order to maximize the open space of the data hall.
7. The ground floor is located at 5mPD. The building has an overall height restriction, including plants of 82.5mPD. See Figure Q1b.
8. The floor to floor between the ground and the first floor is 8.5m, while that between the other data floors is 6.5m.
9. A clear floor to ceiling height for the basement is 4.8m, while that for the ground and data floor is 6.0m and 4.5m respectively.

10. The following should be allowed for in the design of the building:

<u>Floor</u>	<u>Finishes</u>	<u>Building Services/ Ceiling Zone</u>
- Basement	50mm	0.8m
- Ground	200mm	0.6m
- Data Floor	150mm raised floor	0.6m

11. The plants will be located on the roof which is accessible, structures can be provided if required, subject to height restriction.

Imposed Loads

12. The following imposed loadings should be adopted in the design. Other not specified below should be in accordance with the Hong Kong Code of Practice for Dead and Imposed Loads 2011.

- Superimposed Dead Load – Basement (1.5kPa), Ground Floor (5.0kPa) and Typical Floor (3.0kPa), Roof (5.0kPa)
- Superimposed Live Load - Basement (15.0kPa), Ground Floor (10.0kPa) and Typical Floor (20.0kPa) Roof (15.0kPa)

13. The Wind load should be in accordance with the Hong Kong Wind Code (2004 or 2019).

14. A deflection limit control of Span/360 shall be maintained for the Live Load, whilst the limit can be relaxed to Span/240 for the total loads.

15. Assumptions / Exclusions:

- Design of lift / Stair wells / Ramp

Site Conditions

16. The generalized ground conditions are:

Depth	Stratum	Bulk Density	SPT'N' values
Ground level to 2m	Fill	18 kN/m ³	10 to 15
2m to 4m	Alluvial sand	19 kN/m ³	15 to 20
4m to 12m	Completely Decomposed Granite (CDG)	20 kN/m ³	30 to 200
12 to 30m	Completely Decomposed Granite (CDG) / Highly Decomposed Granite (HDG)	20 kN/m ³	≥ 200
≥ 30m	Slightly to moderately decomposed strong rock of material weathering grade III, with a total core recovery of more than 85% of the grade.	25 kN/m ³	UCS values = 25 to 40MPa

The groundwater table is encountered at 3.5m below ground.

Section A

- a. Prepare a design appraisal with appropriate sketches including two distinct and viable solutions for the proposed data centre including two viable foundation systems. Clearly indicate the functional framing, fire proofing, load transfer and stability aspects of each scheme. Identify the solution you recommend and give reasons for your choice.

(30 marks)

- b. Explain how the building structure will resist wind load including detailed description of the structural wind frame(s), design assumptions and how the floor deflections are to be checked and controlled.

(10 marks)

Section B

For the solution recommended in Section A:

- c. Prepare sufficient design calculations to establish the form and size of all the principal structural elements including the foundations.

(20 marks)

d. Prepare general detailed structural framing plans (typical floor, ground floor and basement/foundation) to show the dimensions, layout, movement joints (if any), disposition of the structural elements and critical structural details (including major beam penetrations, if any) for estimating purposes.

(20 marks)

e. Prepare sufficient details of the critical elements / connections such as columns, beams, column/beam, column/slab connections etc. reflecting the chosen design solution.

(10 marks)

f. Prepare a detailed project programme for the design and construction of the project including a method statement for controlling the tunnel movements during construction.

(10 marks)

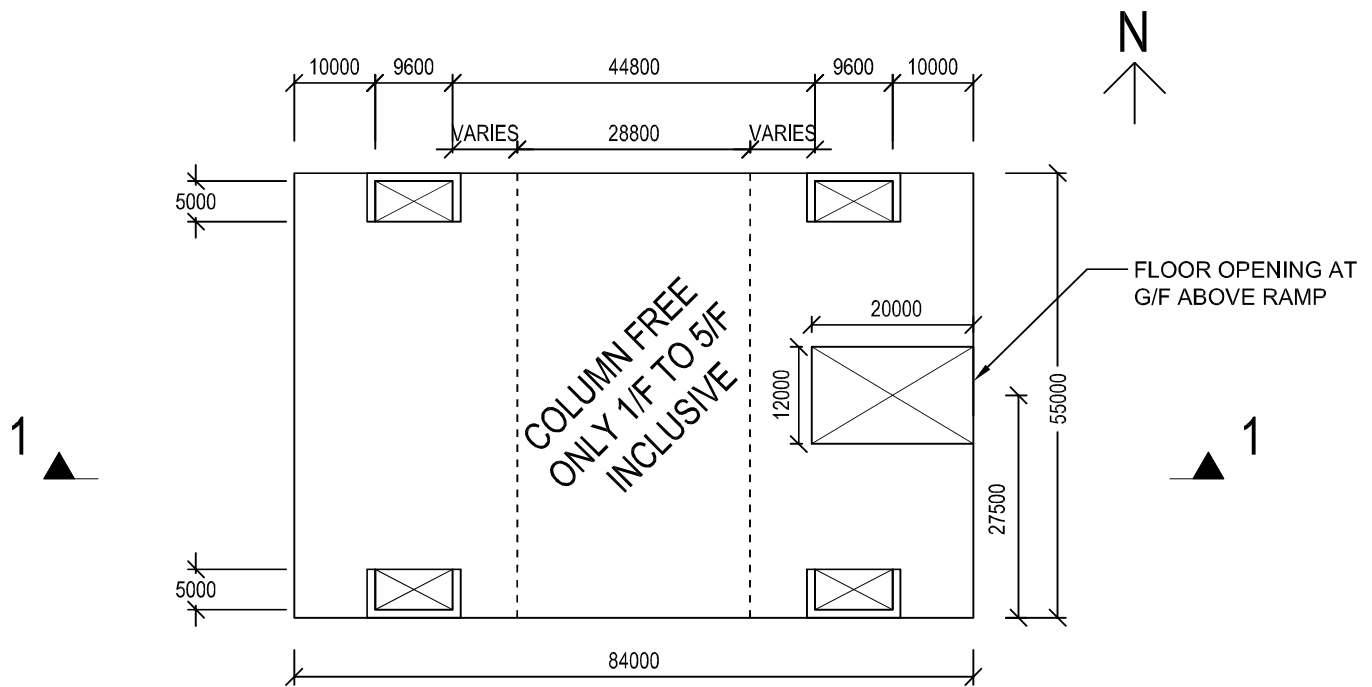
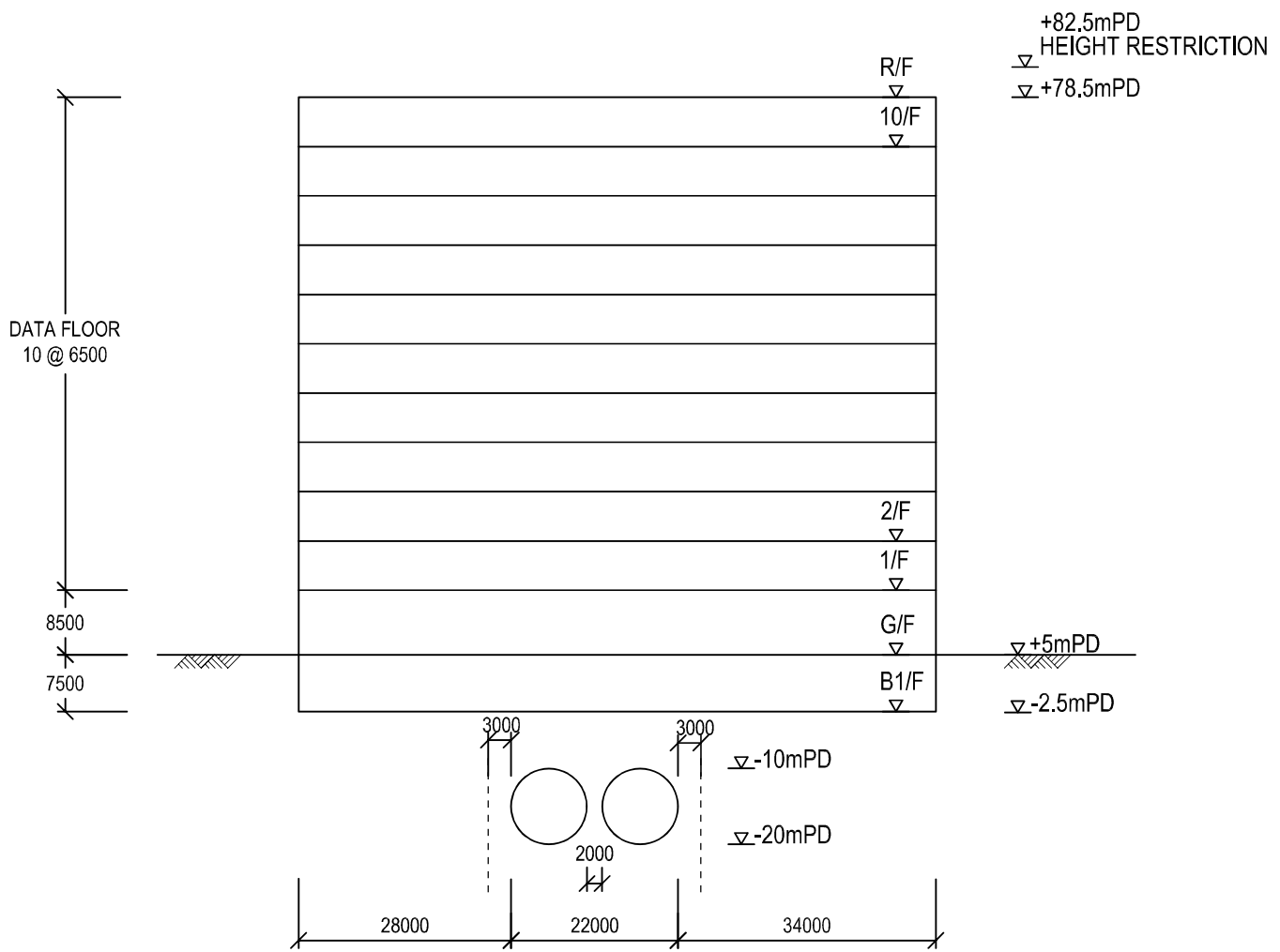

FIGURE Q1a



**SECTION 1-1
FIGURE Q1b**

Question 2 Conversion of Factory Building to Office with Roof Top Extension

Client's Requirements

The following client's requirements must be met:

1. An existing eight storeys factory building constructed in 80s is to be converted to an office building for general use with 3 storeys extension over the existing flat roof and a signboard at new flat roof for all four elevations. See Figures Q2.
2. The whole existing factory building is to be vacant for construction.
3. A new stair and lift core is to be constructed in the area bounded by grids B-C and grids 3-4. The existing stair and lift core, and the structures between grids D-E and grids 1-5 is to be demolished from ground level up after the completion of the new extension and the lift and stair core.
4. The proposed use of the new building with the minimum clear headroom, finishes & E&M services zone and fire resistance rating is listed as follows:

Floor Mark	Usage	Minimum Clear Headroom * (m)	Finishes, & E&M Services zone (m)	Fire Resistance Rating
R/F	Accessible roof/Signage			
9/F – 11 /F	Office	3.0	0.4	2 hours
1/F – 8/F	Office	2.8	0.4	2 hours
G/F	Shop and Lobby	4.0	0.6	2 hours

* The minimum clear headroom is the floor height clear of all structures, finishes, and E&M Services.

5. Information of the existing building are given as follows.

Floor Mark	Usage	Designed Imposed Load (kPa)	Designed Superimposed Dead Load (kPa)	Fire Resistance Rating
R/F	Inaccessible roof	0.75	2.0	2 hours
1/F – 8/F	Factory	10	2.5	2 hours
G/F	Loading and Unloading	20	2.0	2 hours

Foundation: Caisson rest on rock with allowable bearing pressure 5000kPa.

6. For the new extension above 9/F, the column to column spacing should not be more than 7.5m centre to centre.
7. The flat roof at 9/F outside of office as indicated on plan is for green landscape lawn with planter soil 400mm thick and 200mm thick waterproofing and insulation layer.

Imposed Loads

8. The imposed loads shall be in accordance with the latest version of the Code of Practice for Dead and Imposed Loads in Hong Kong, unless specified.

Wind Loads

9. The existing building was designed based on the Code of Practice on Wind Effects in Hong Kong 1983.
10. According to APP117 of Practice Notes for AP/RSE (PNAP), the structural adequacy of an existing building or part thereof, as may be affected by proposed A&A works may, subject to the following requirements, be checked according to the then prevailing Building Regulations and codes of practice to which they were designed:
 - (a) Wind Calculations
In the case of A&A works involving:
 - i. partial or total removal of existing major wind resisting walls or frames, which would result in a reduction in their stiffness by 5% or more, or
 - ii. the extension of building dimensions which would result in an increase of 10% or more of the wind exposure areas of a building, the structural adequacy of the building due to wind should be checked based on the current wind code (Code of Practice on Wind Effects in Hong Kong 2004 or 2019)

Site Conditions

11. The site is located at Kwai Chung New Territories and with flat ground level at +6.5mPD.
12. On the two sides of the site and separating by a lane of 3 m width, there are two 8 storeyed factory buildings with caisson foundation. The front and rear of the site are streets of 6m width.

13. Ground conditions:

From +6.5mPD – +0mPD	Loose Fill, SPT average N-value < 10
From +0mPD – -8mPD	Medium dense sand, SPT average N-value = 30
From -8mPD – -20mPD	Completely decomposed granite, SPT N-value > 200
Below -20mPD	Moderately decomposed granite with total core recovery greater than 85%

14. The highest possible groundwater level is at +6.5mPD.

Omit from Consideration

15. Design for staircases, cladding, window systems, façade, protective barrier, and roof top signboard is not required. However, the loading effect of these structures should be considered.

16. Detailed layout and design of the non-structural elements inside the service core.

Section A

a. Prepare two distinct and viable solutions for the proposed conversion works including viable schemes for lateral and gravity loads stability and provide your key consideration. Clearly indicate the functional framing, load transfer and stability aspects of each scheme to meet all client's requirements. Identify the solution you recommend and give reasons for your choice.

(30 marks)

b. Give a brief assessment on the effects of the proposed alterations and additions works and suggest strengthening solution if necessary for the following.

- 1) The existing caisson foundation.
- 2) The existing beam-column frame after demolishing the structures between grids D-E and grids 1-5 (portion B).

(10 marks)

Section B

For the solution recommended in Section A:

- c. Prepare sufficient design calculations to establish the form and size of all the principal structural elements for superstructure above 8/F, including transfer (if any) and critical structures.

(10 marks)
- d. Prepare dimensional framing plans and sections for superstructure above 8/F, to show the general arrangement of the structural elements including transfer (if any) and critical structures.

(25 marks)
- e. Prepare the structural details for the principal structural elements at above 8/F including transfer (if any) and critical structures for estimating purposes.

(10 marks)
- f. Prepare a detailed method statement for the demolition of the existing structures.

(10 marks)
- g. Prepare a detailed construction program covering essential activities from commencement of all protection and precaution measures to completion of structural works including the removal of the existing structures.

(5 marks)

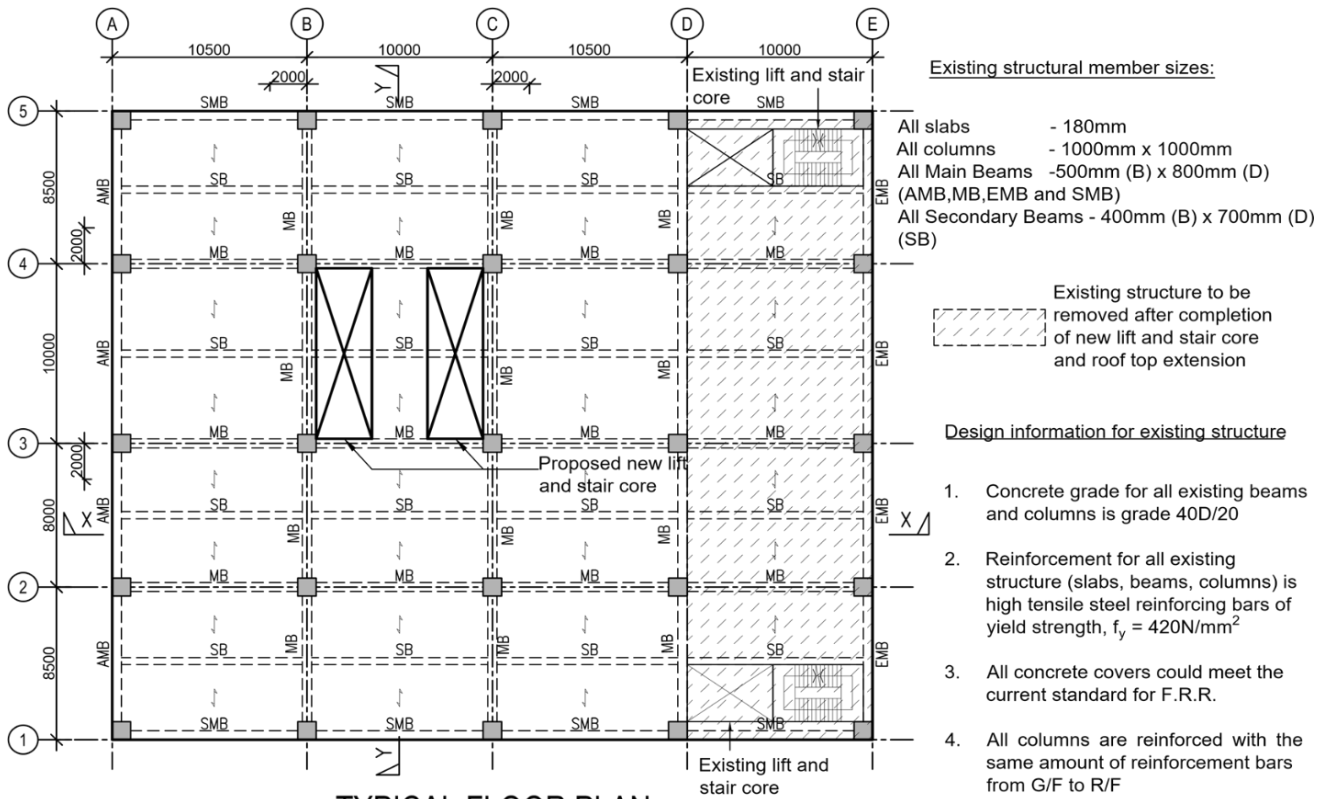
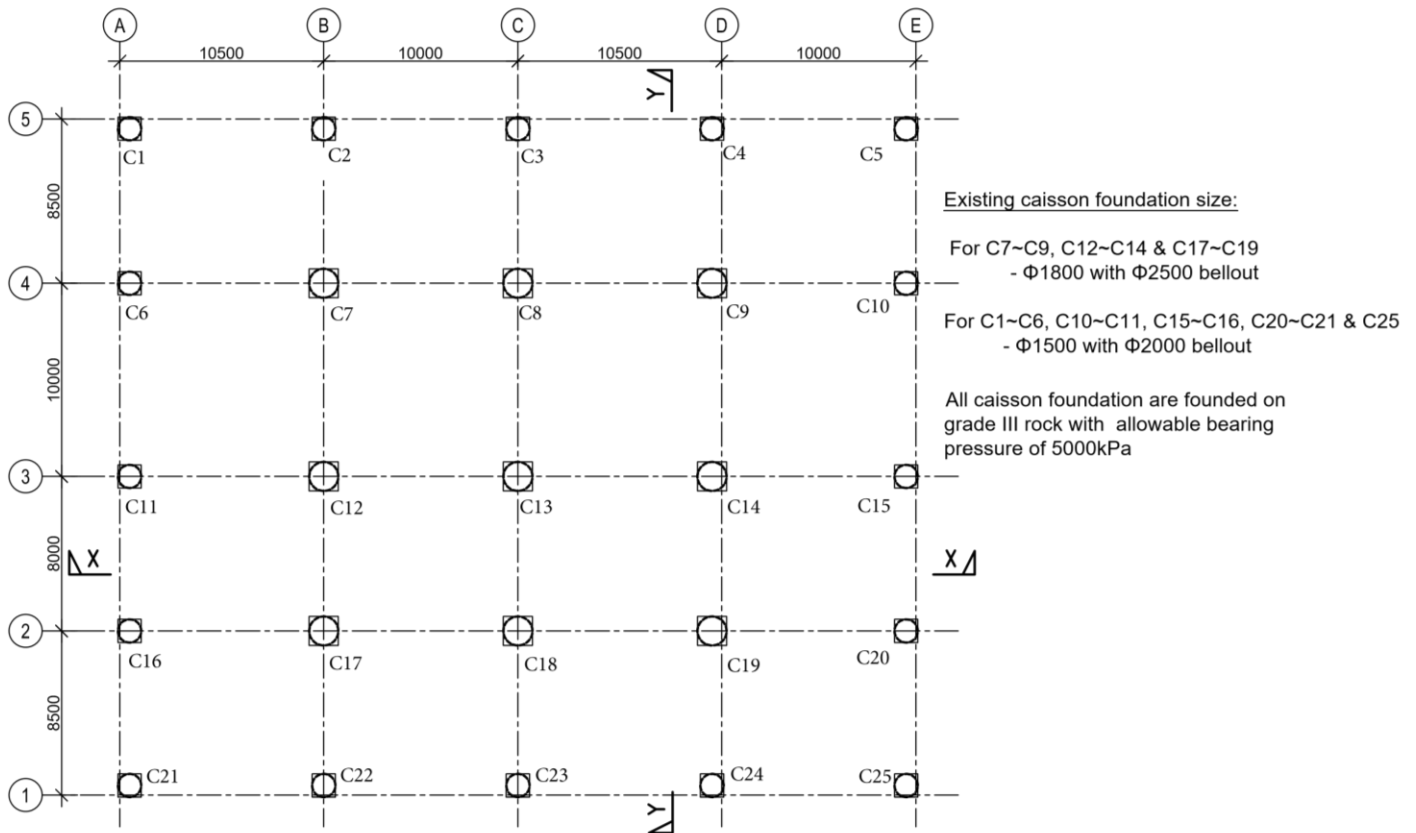
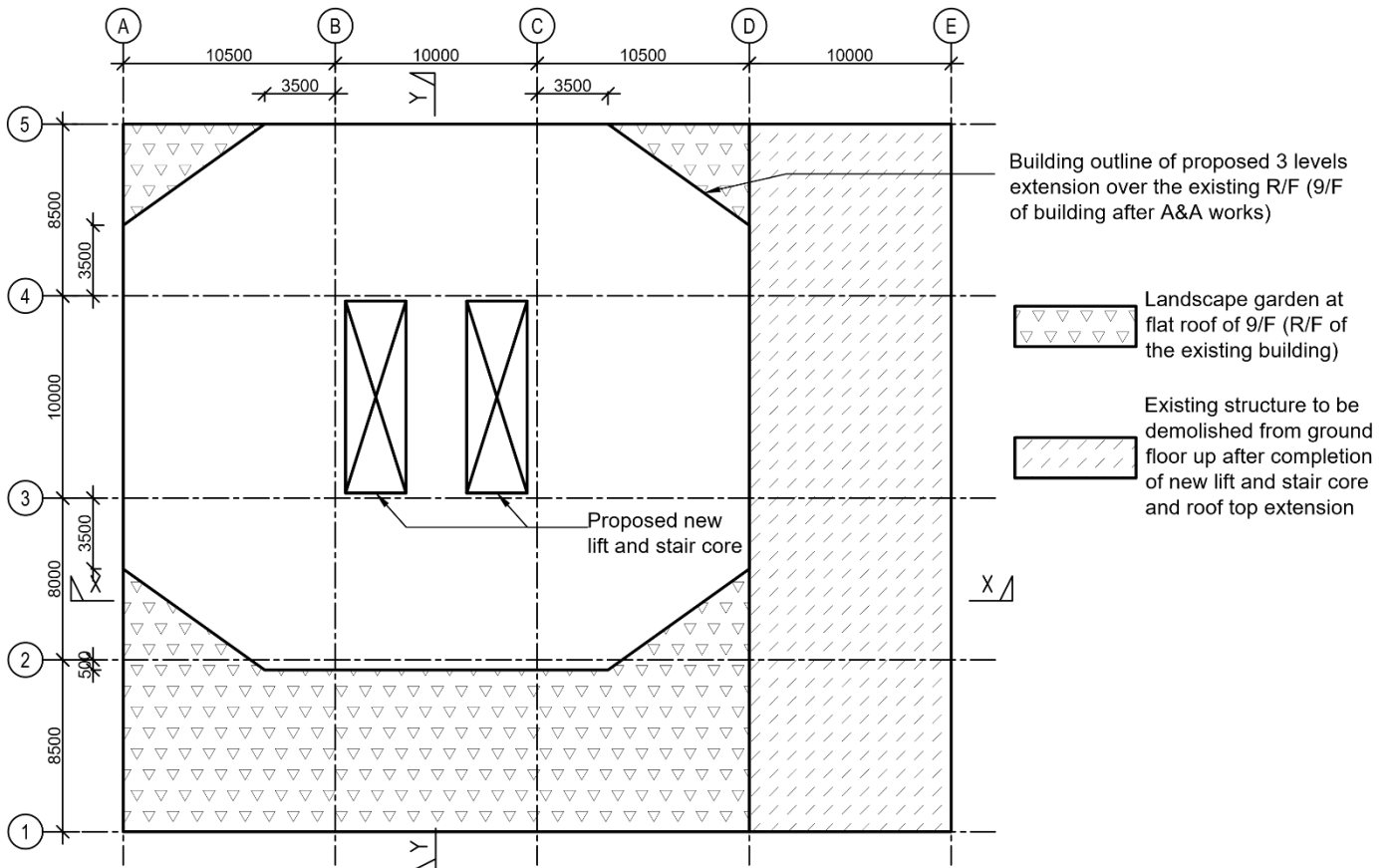

FIGURE Q2-A TYPICAL FLOOR PLAN (EXISTING BUILDING)



EXISTING CAISSON FOUNDATION PLAN

FIGURE Q2-B



**LAYOUT OF PROPOSED ROOF TOP EXTENSION AND
9/F PLAN (R/F PLAN OF EXISTING BUILDING)**

FIGURE Q2-C

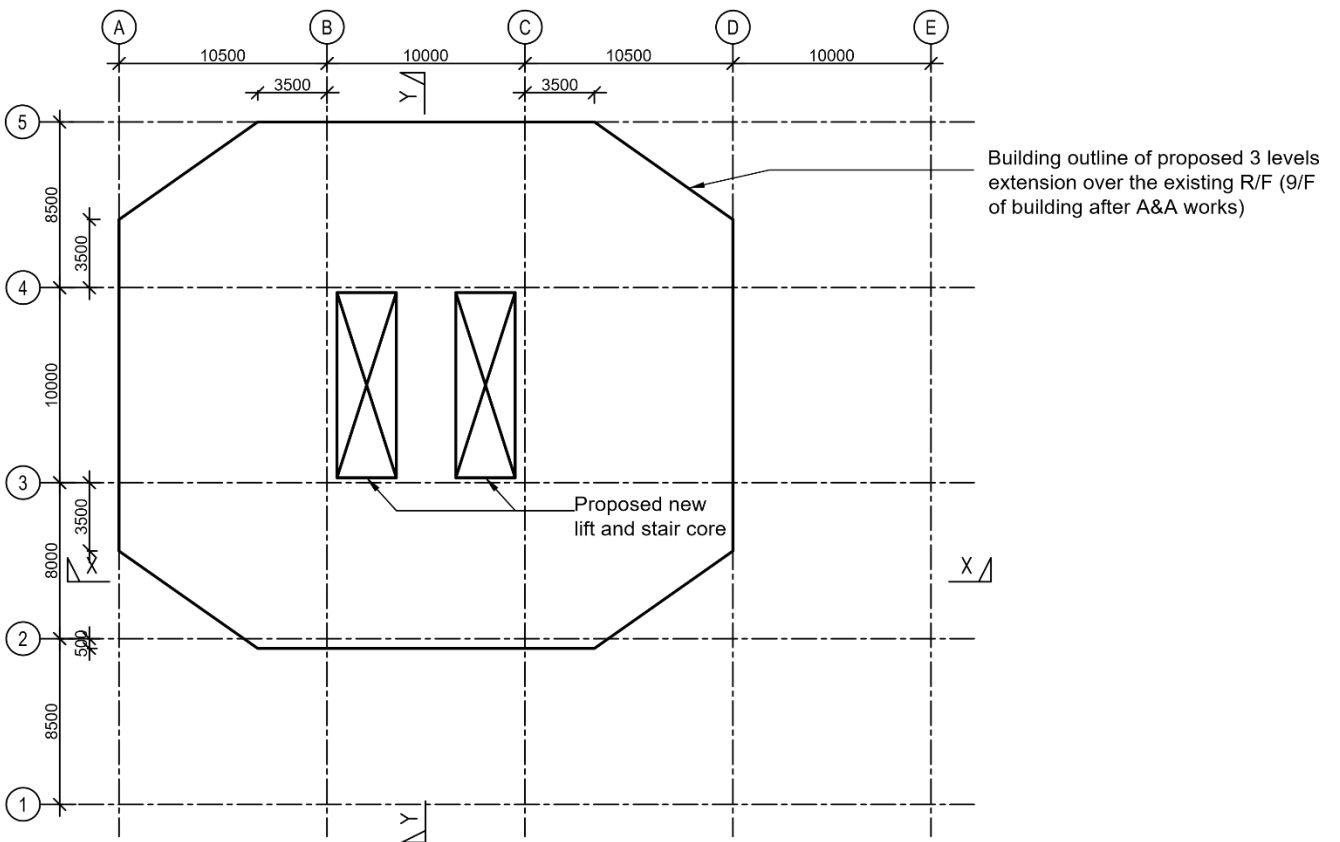

**LAYOUT OF PROPOSED ROOF TOP EXTENSION
(10/F ~ R/F PLAN OF BUILDING AFTER A&A)**

FIGURE Q2-D

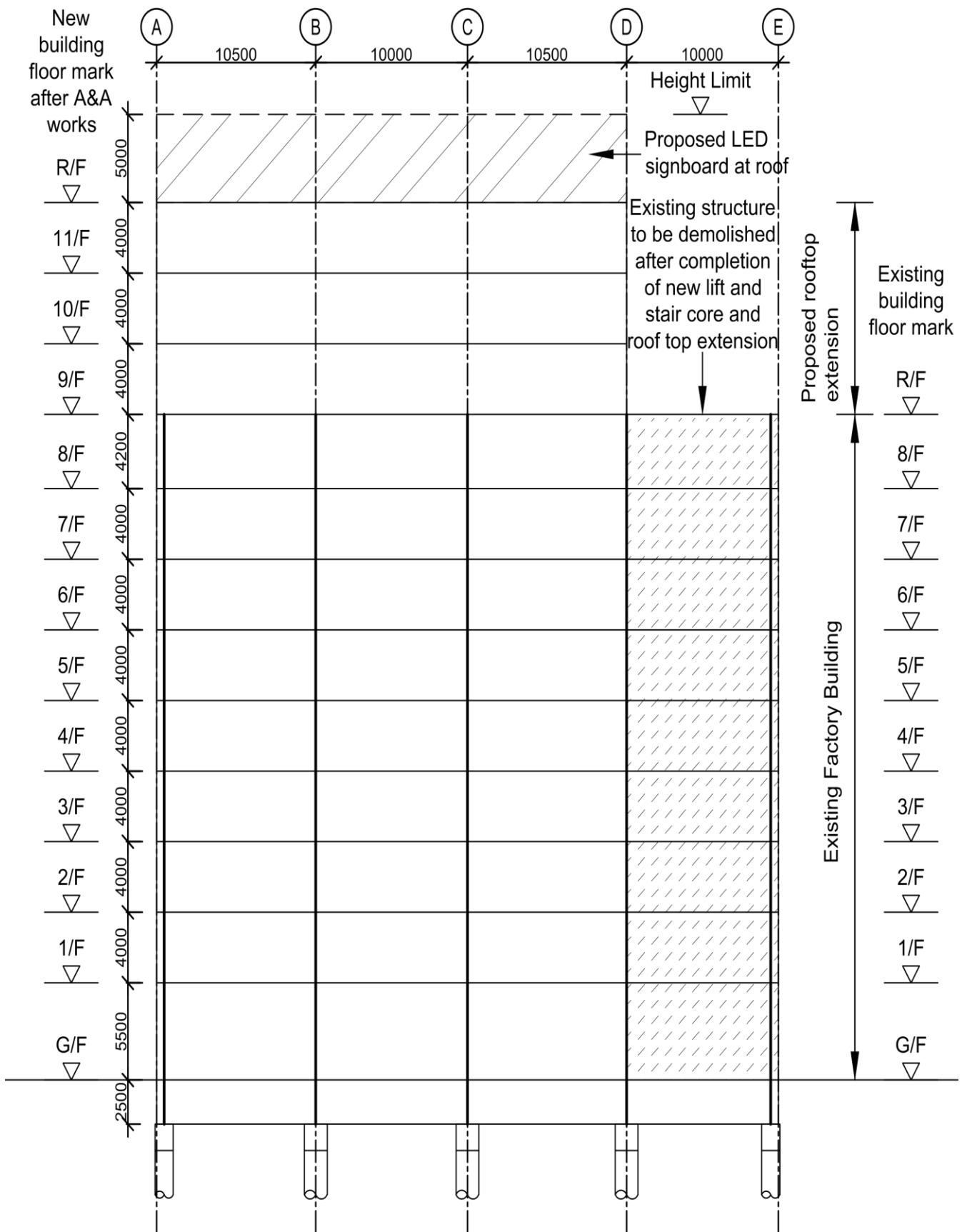

SECTION X X
 FIGURE Q2-F

Question 3 Office Building with Open Sky Garden

Client's Requirements

The following client's requirements must be met:

1. An office building with open sky garden is to be constructed within the developed area of Hong Kong. See Figure Q3.
2. This office building includes an upper block tower and a lower block tower of plan dimension 28m x 28m and 37m x 37m respectively. An open skygarden is located at roof of lower block tower with minimum headroom of 12 to 16m.
3. The proposed use of the office building with the minimum headroom requirements and fire resistance rating is listed as follows:

Floor Mark	Usage	Minimum Clear Headroom* (m)	Fire Resistance Rating	Finishes & E/M Services Zone (m)
Main Roof	Inaccessible	N/A	N/A	N/A
11/F – 20/F	Office (Upper Block)	3.2	2 hours	0.3
10/F	Sky Garden	Below the false ceiling as indicated in Figure Q3	2 hours	N/A
1/F – 9/F	Office (Lower Block)	3.2	2 hours	0.3
M/F	F&B	3.0	2 hours	0.5
G/F	F&B	4.5	2 hours	0.5
G/F	Lobby	7.0	2 hours	0.5
B/F	F&B	3.0	4 hours	0.5

* The minimum clear headroom is the floor height clear of all structures, finishes and building services.

4. The restrictions on the location of vertical structural elements are as follows:

Floor Mark	Area	Restrictions
11/F – 20/F	Office	- Minimum columns centre to centre spacing is 9.0m. - Minimum clear width of 4.0m to be maintained at all locations.
10/F	Sky Garden	- No restrictions.
G/F to 10/F	Office & F&B	- Minimum columns centre to centre spacing is 12.0m. - Minimum clear width of 4.0m to be maintained at all locations.
G/F	Lobby	- No internal column permitted.
B/F	F&B	- No restrictions.

5. The main roof structure above upper tower shall not be inverted.
6. No intermediate horizontal supports or ties are permitted at the exposed columns at sky garden level.
7. For cantilever structure (if any), maximum cantilever span to be less than 4.0m from centre to centre.

Imposed Loads

8. The imposed loads shall be in accordance with the latest version of the Hong Kong Code of Practice for Dead and Imposed Loads.
9. Superimposed dead load of 20 kPa should be allowed for the Sky Garden at 10/F.

Wind Loads

10. The wind loads shall be in accordance with the Code of Practice on Wind Effects in Hong Kong 2004 or 2019.

Site Conditions

11. Adjacent to the eastern boundary of the site is a 5-storey religious building with shallow footing foundation.

12. Ground conditions:

From +6mPD to +2mPD	Loose Fill, SPT average N-value = 10 [Category 4(d)] ^{Note 1}
From +2mPD to -40mPD	Medium dense sand, SPT average N-value = 30 [Category 4(c)] ^{Note 1}
From -40mPD to -50mPD	Completely decomposed granite, SPT N-value > 200 [Category 3] ^{Note 1}
Below -50mPD	Moderately decomposed granite with total core recovery greater than 85% [Category 1(c) rock] ^{Note 1}

Note 1: Categories of soil/rock refer to Table 2.1 of Code of Practice for Foundation 2017.

13. The highest possible groundwater level is at +6mPD.

Omit from Consideration

14. Detailed layout and design of the structure inside the service core.

15. False ceiling above the sky garden.

Section A

a. Prepare a design appraisal with appropriate sketches including two distinct and viable solutions for the proposed office building including two viable foundation schemes. Indicate clearly the functional framing, load transfer and stability aspects of each scheme to meet all client's requirements. Identify the solution you recommend and give reasons for your choice.

(30 marks)

b. Explain how the structure will resist wind load including detailed description of the structural wind loads and design assumptions. Prepare a detailed wind load calculation and stability checking for the proposed office building.

(10 marks)

Section B

For the solution recommended in Section A:

- c. Prepare design calculations to establish the form and size of all principal structural elements for superstructure from G/F to R/F including transfer structures, slender columns and critical structures (if any).
(15 marks)
- d. Prepare full dimensional framing plans for G/F, typical floors of lower and upper office block, and all levels with transfer and critical structures (if any).
(20 marks)
- e. Prepare structural details for the principal structural elements from G/F to R/F including transfer and critical structures (if any), for cost estimation purpose.
(10 marks)
- f. Prepare the design calculation for the building foundation.
(5 marks)
- g. Prepare a preliminary foundation layout plan.
(5 marks)
- h. Prepare an outline construction program covering essential activities from commencement of foundation/ basement to the completion of structural works.
(5 marks)

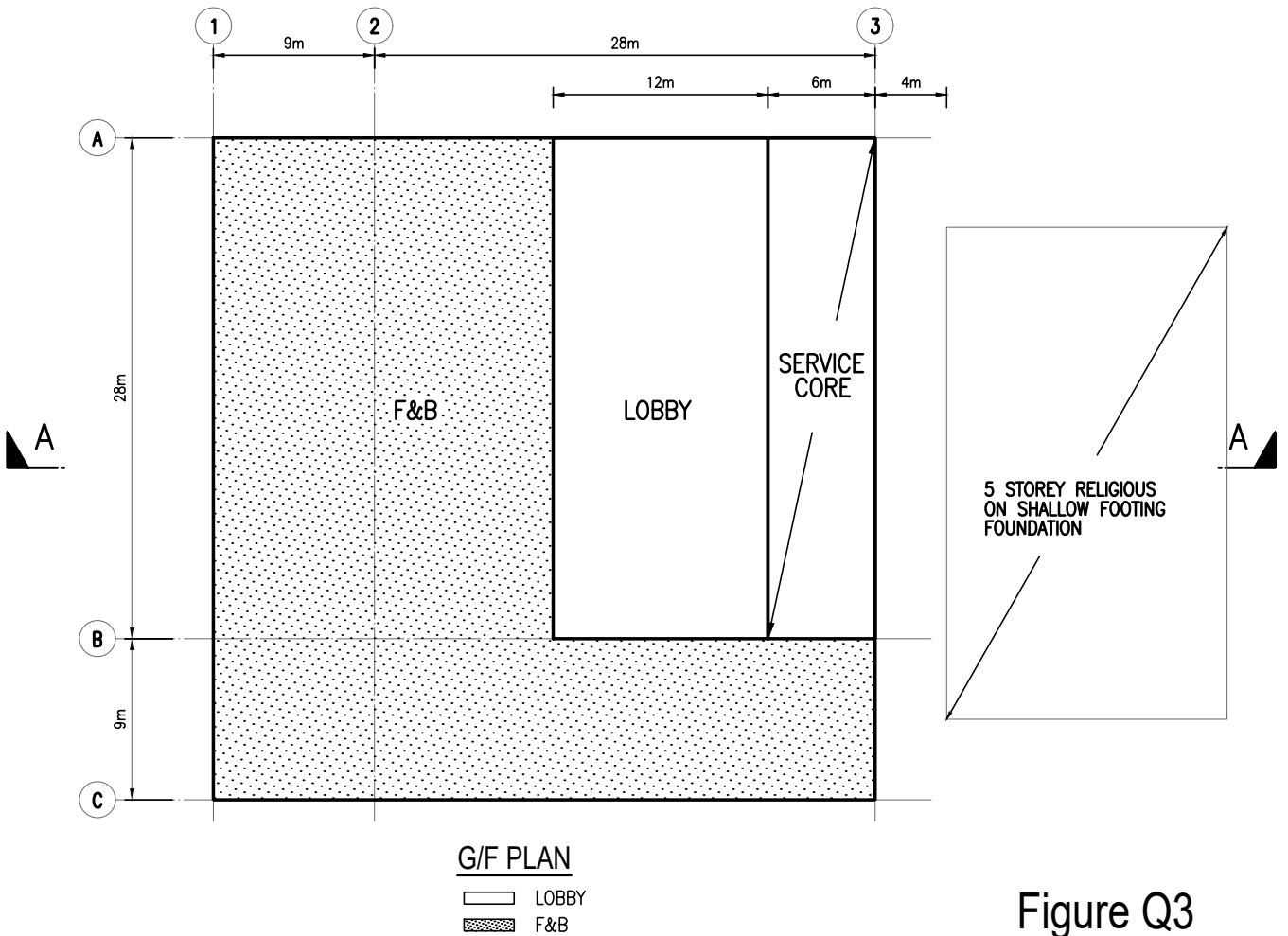
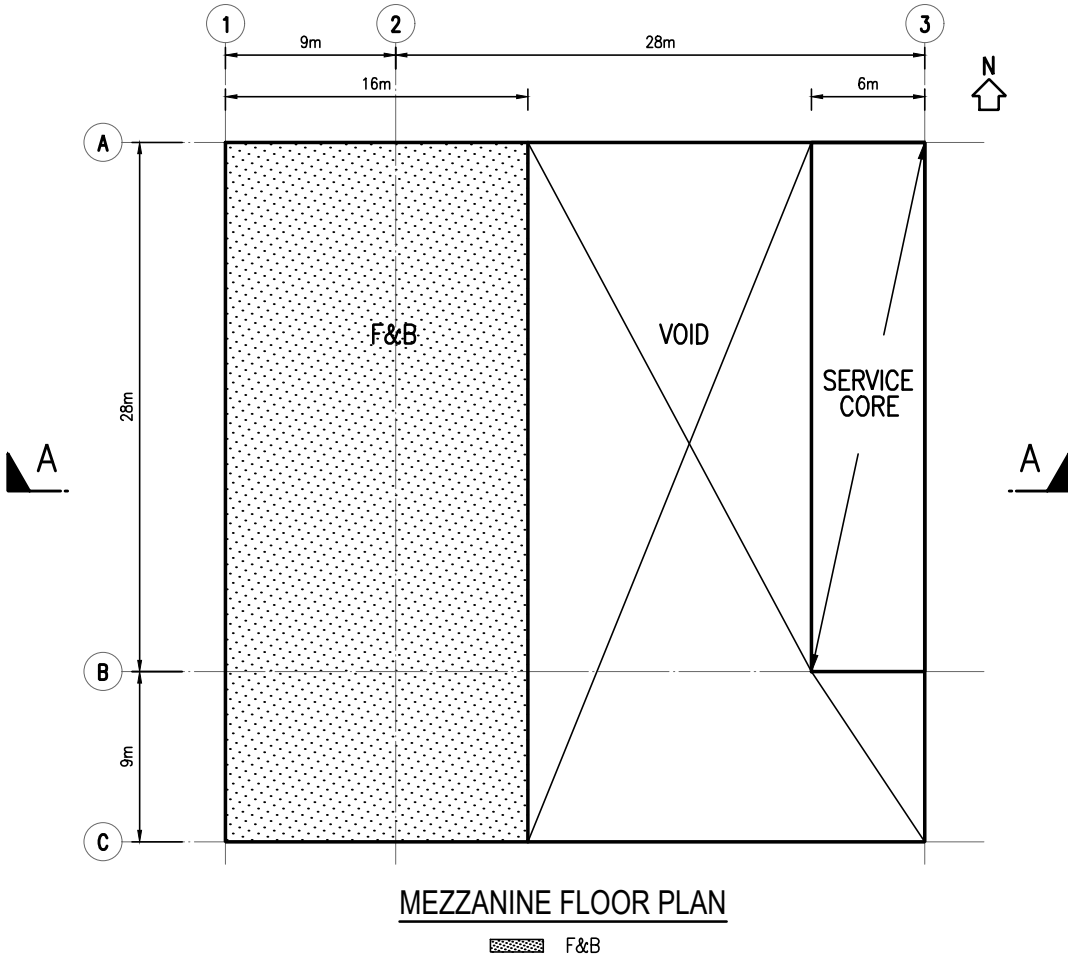
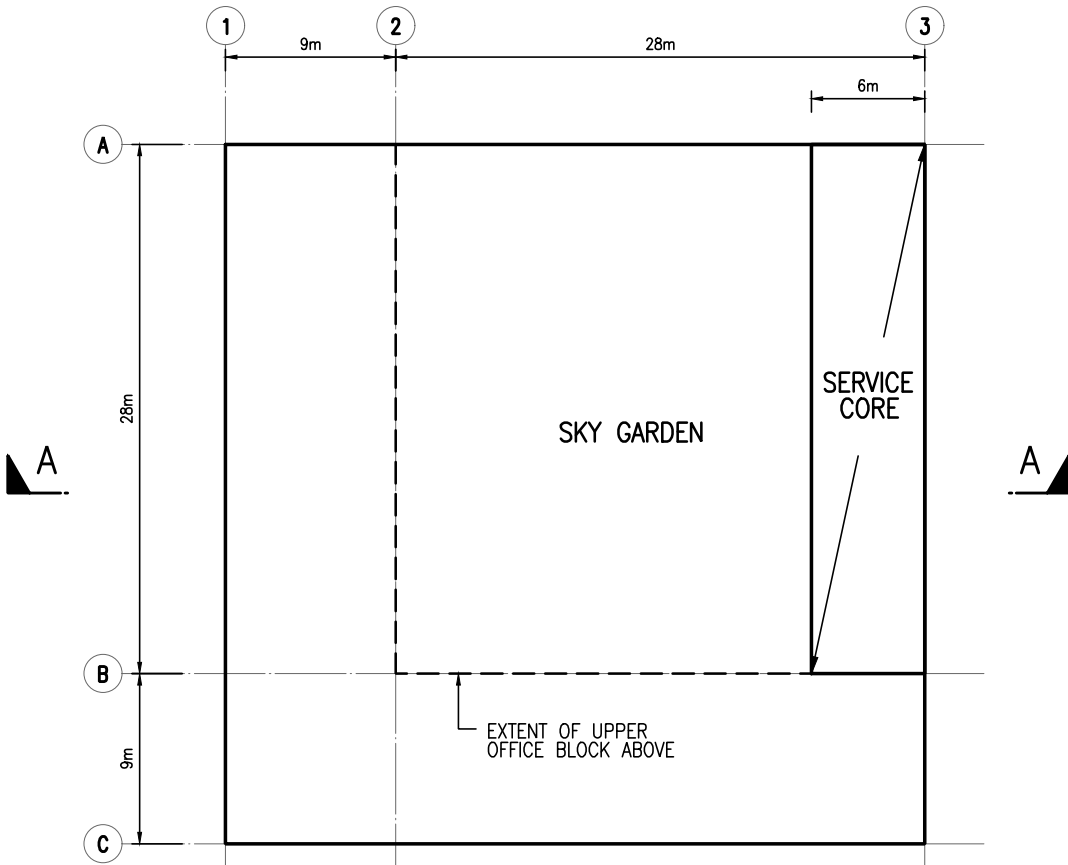
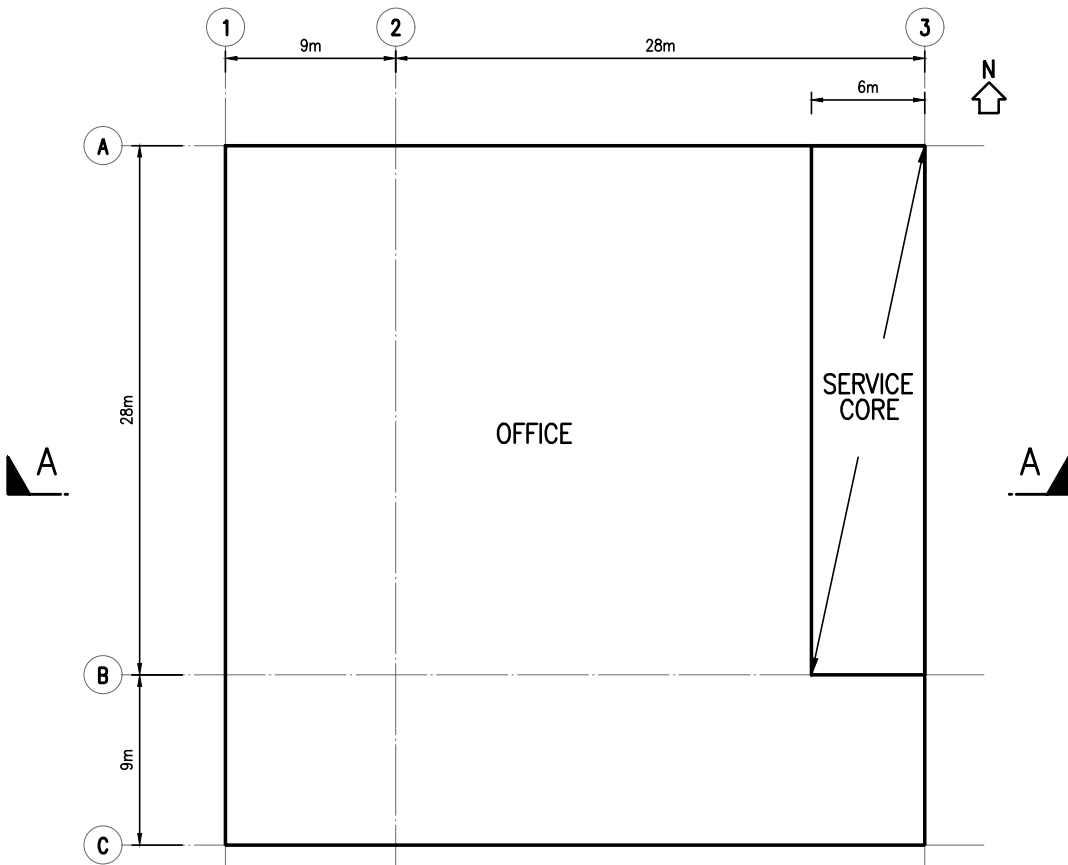

Figure Q3



SKY GARDEN FLOOR PLAN

□ SKY GARDEN



LOWER OFFICE BLOCK - TYPICAL FLOOR PLAN

□ OFFICE

Figure Q3

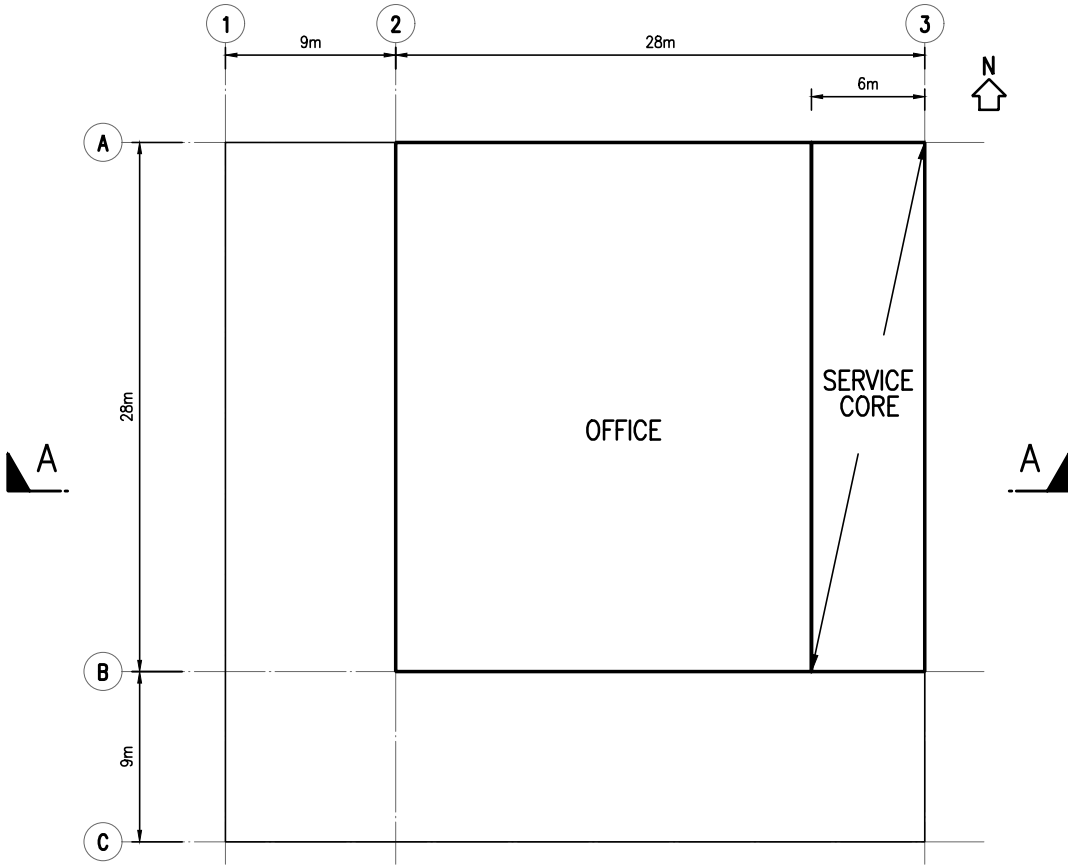

UPPER OFFICE BLOCK - TYPICAL FLOOR PLAN

□ OFFICE

Figure Q3

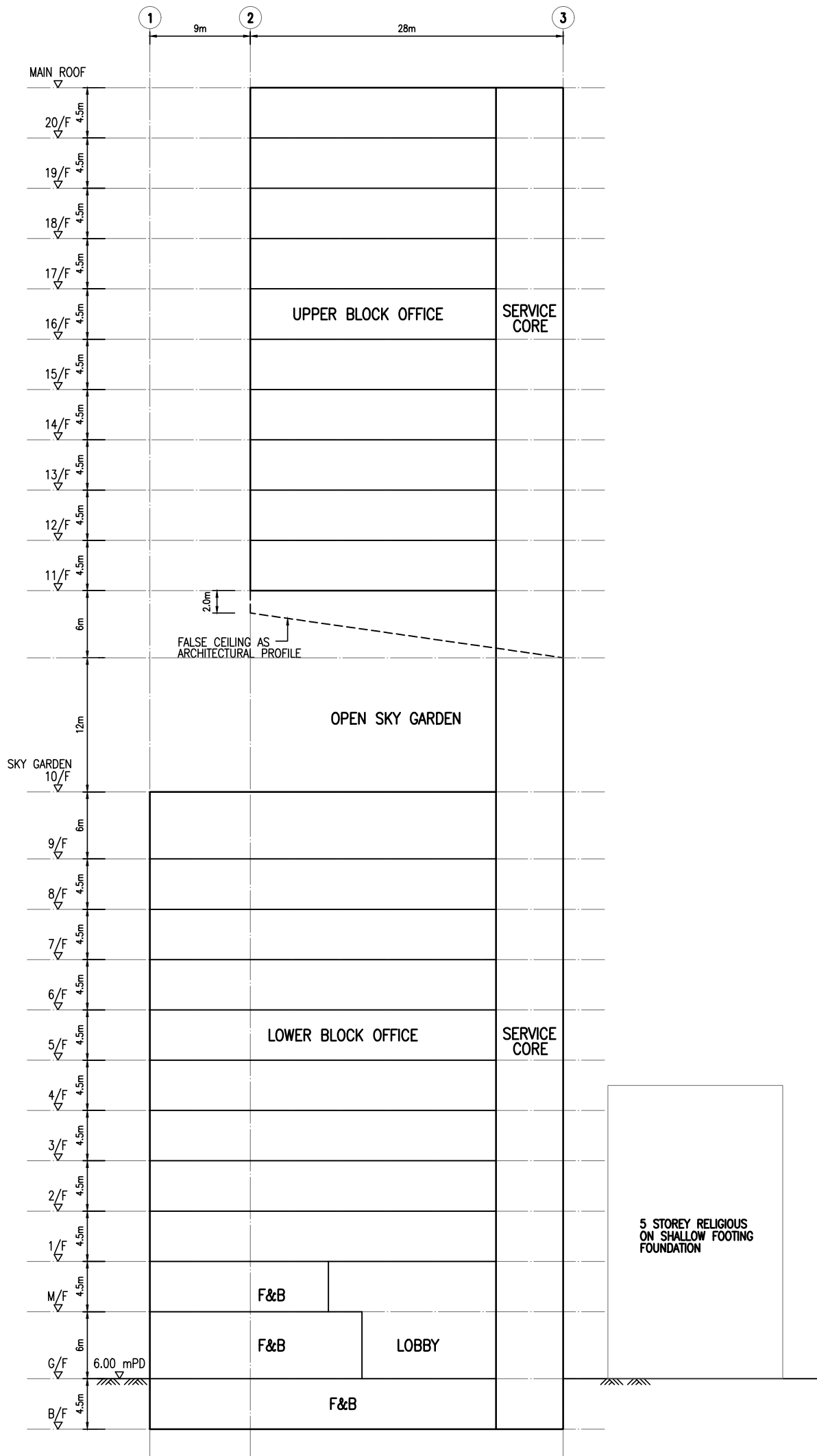

Figure Q3

Question 4 Highway Bridge

Client's Requirements

The following client's requirements must be met:

1. A dual single lane existing bridge as shown in Figure Q4 has reached its capacity and needs to be enhanced to cater for traffic flow across the two sides of the river and it is proposed to build a new bridge alongside with the existing. The existing alignment of the bridge is to be at a high point in the middle to allow for navigation channel. (see existing elevation as shown).
2. As required by environmental requirement and land constraint, the proposed horizontal and vertical road alignment is proposed to be the same as the existing bridge with navigation channel in the middle. The proposed abutments need to be at the same alignment of the existing abutments.
3. The cross section of the new bridge is to have a two lanes carriageway with 1.0m of marginal strip on the near side and 0.5m on the off side. No columns are permitted in the navigation channel and 5.0m to the left and right of the existing column in elevation and no movement joint is to be allow within the span of the new bridge.
4. The existing navigation channel is to remain in service as much as possible during the construction of the new bridge. The channel may be closed between 10:00pm on Saturday evening to 06:00am on the following Sunday morning.
5. The minimum requirements on clear headroom for navigation is as follows

<u>Location</u>	<u>Min. Clear Headroom (m)</u>
Under Highway Viaduct	10.96 m above high water table

6. Closure of one lane of highway for construction is allowed each night between mid night and 06:00am.

Design Requirements

7. The structural design shall be in accordance with the latest version of the Structures Design Manual for Highways and Railways published by the Highways Department of the HKSAR Government.

Imposed Loads

8. The loading from the railing barrier to be 5 kN/m each side.

Wind Loads

9. The wind loads shall be in accordance with the requirements in the latest version of the Structures Design Manual for Highways and Railways.

Site Conditions

10. The site is located at open area with Degree 3 of exposure to wind.

11. Ground conditions below the seabed levels are:

0m – 5m	Loose Alluvium sand, SPT N-value = 0 – 10 {Category 4(d)} ^{Note 1}
5m – 20m	Medium dense soil, SPT N-value = 10 – 40 {Category 4(c)} ^{Note 1}
20m – 35m	Very dense soil, SPT N-value >50{Category 4(d)} ^{Note 1}
35m and below	Moderately decomposed granite with total core recovery >85% {Category 1(c)} ^{Note 1}

Note 1: Categories of soil/rock refer to Table 2.1 of Code of Practice for Foundation 2017

Omit from Consideration

12. Design against ship impact and calculations for railings and abutment for the proposed bridge.

Section A

- a. Prepare a design appraisal with appropriate sketches indicating two distinct and viable solutions for the spans of the proposed highway bridge including two viable foundation schemes. Indicate clearly the functional framing, load transfer and stability aspects of each scheme to meet all client's requirements. Identify the solution you recommend and give reasons for your choice.

(30 marks)

- b. Explain how the structure will resist wind load including detailed description of the wind loads and design assumptions. Prepare detailed wind load calculations for the proposed highway bridge.

(10 marks)

Section B

For the solution recommended in Section A:

- c. Prepare sufficient design calculations to establish the form and size of all the principal structural elements including the foundation.

(20 marks)

- d. Prepare foundation plans and details, framing plans, sections and elevations to show the dimensions, layout and disposition of the structural elements and critical details for cost estimating purposes.

(20 marks)

- e. Prepare a detailed method statement covering essential activities for the construction of the superstructure and sub structures of the bridge including foundation works.

(10 marks)

- f. Prepare a detailed construction program covering essential activities from commencement of foundation to completion of structural works.

(10 marks)

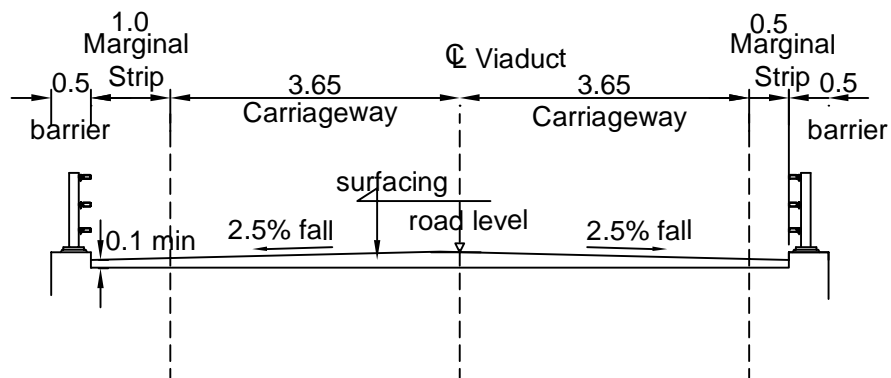
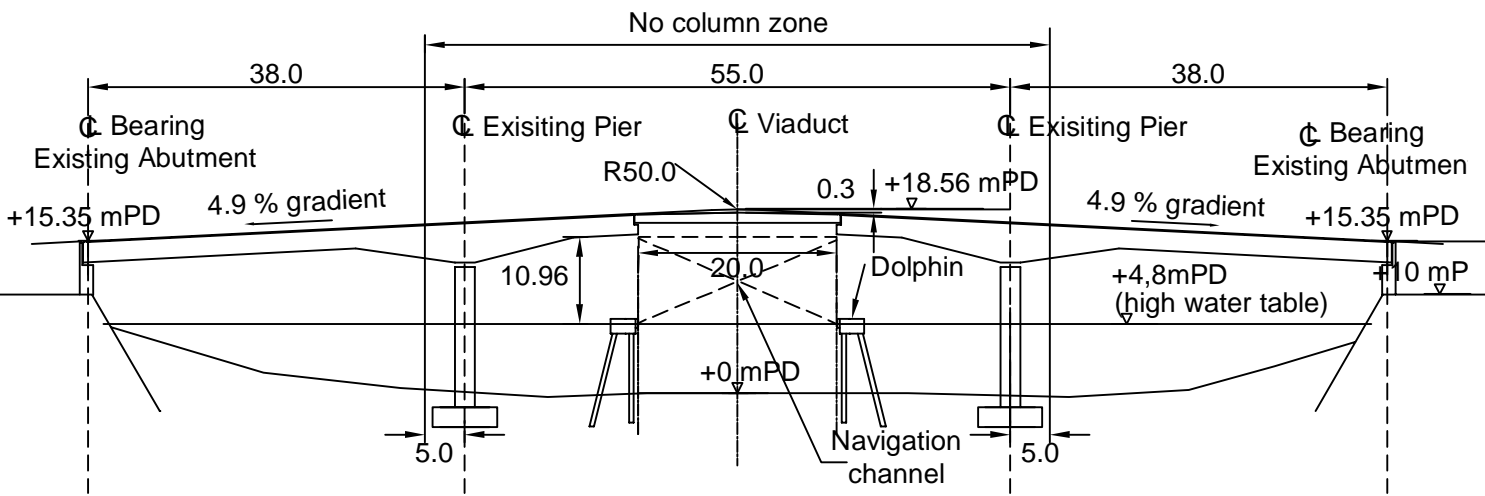
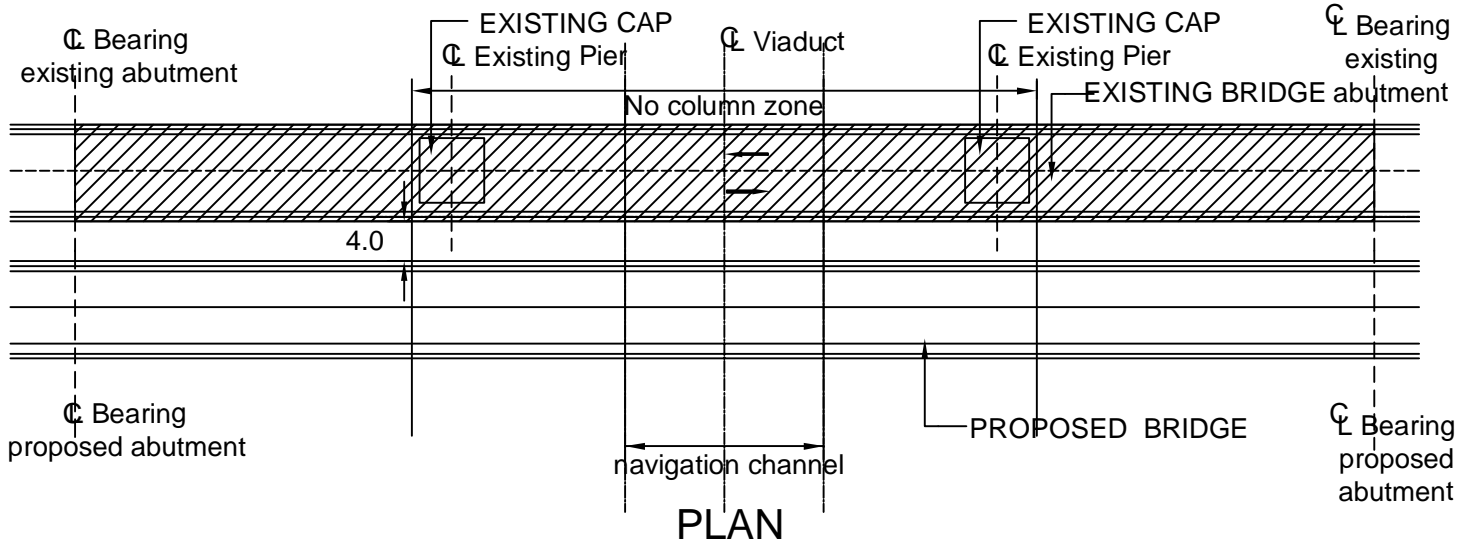

Note: All units are in metre

FIGURE Q4

Question 5 Grand Stand with Roof

Client's Requirements

The following client's requirements must be met:

1. A new covered grand stand is proposed to be built at a coastal area with ground level at +6mPD as shown in Figure Q5a.
2. The roof of grand stand shall be constructed in light weight material.
3. The minimum clear headroom of the roof is 20m measured from the ground level.
4. There is no height limitation for structure.
5. Footprint of the grand stand is 120m in length and 30m in width.
6. Occasional above ground structural elements for overall stability of structure can be built outside the footprint of the grand stand with a 5m zone at the rear and 10m zones on both shorter sides as shown in Figure Q5b.
7. For completely unobstructed view towards the football pitch, columns will not be allowed along the front edge of the grand stand or within the seating or corridor areas.
8. The minimum column spacing along the length of the grand stand shall be 20m from centre to centre.
9. No foundation (including pile caps) shall be constructed within 1.5m below the ground level and built outside the site boundary.
10. At least 25% area of the roof should be glazed for natural lighting.
11. Roof should be inclined at 5 degrees minimum to avoid rainwater ponding.

Imposed Loads

- | | |
|-------------------|----------------------|
| 12. Roof: | 2kN/m ² |
| Services in roof: | 0.5kN/m ² |
| Ground Floor: | 5kN/m ² |

Wind Loads

13. The wind loads shall be in accordance with the Code of Practice on Wind Effects in Hong Kong 2004 or 2019.

Site Conditions

- | | |
|-------------------|---|
| 14. +6mPD to 0mPD | Loose fill with SPT N-value <10 |
| 0mPD to -20mPD | Medium Dense sand with SPT N-value from 10 to 50 |
| Below -20mPD | Slightly to moderately decomposed strong rock of material weathering grade III or better, with total core recovery greater than 85% |

Ground water is encountered at 2m below ground level

Omit from Consideration

15. Design of seating and roof glazing

Section A

- a. Prepare a design appraisal with appropriate sketches indicating two distinct and viable solutions for the proposed grand stand including two viable foundation schemes. Clearly indicate the function framing, load transfer and stability aspects of each scheme to meet all client's requirements. Identify the solution you recommend and give reasons for your choice.
- (30 marks)**
- b. Explain how the structure will resist wind loads including detailed description of the wind loads and design assumptions. Prepare detailed wind load calculations for the proposed grand stand.
- (10 marks)**

Section B

For the solution recommended in Section A:

- c. Prepare sufficient design calculations to establish the form and size of all the principal structural elements including the foundation. In calculation of wind loads, considerations on torsional forces and cross-wind base moment and dynamic effect are not required.
- (20 marks)**
- d. Prepare framing plans, sections and elevations to show the dimensions, layout and disposition of the structural elements and critical details and foundation plan for cost estimation purpose.
- (20 marks)**

e. Prepare a detailed method statement covering essential activities for the safe construction of the grand stand including foundation works.

(10 marks)

f. Prepare a detailed construction programme covering essential activities from commencement of foundation to completion of structural works.

(10 marks)

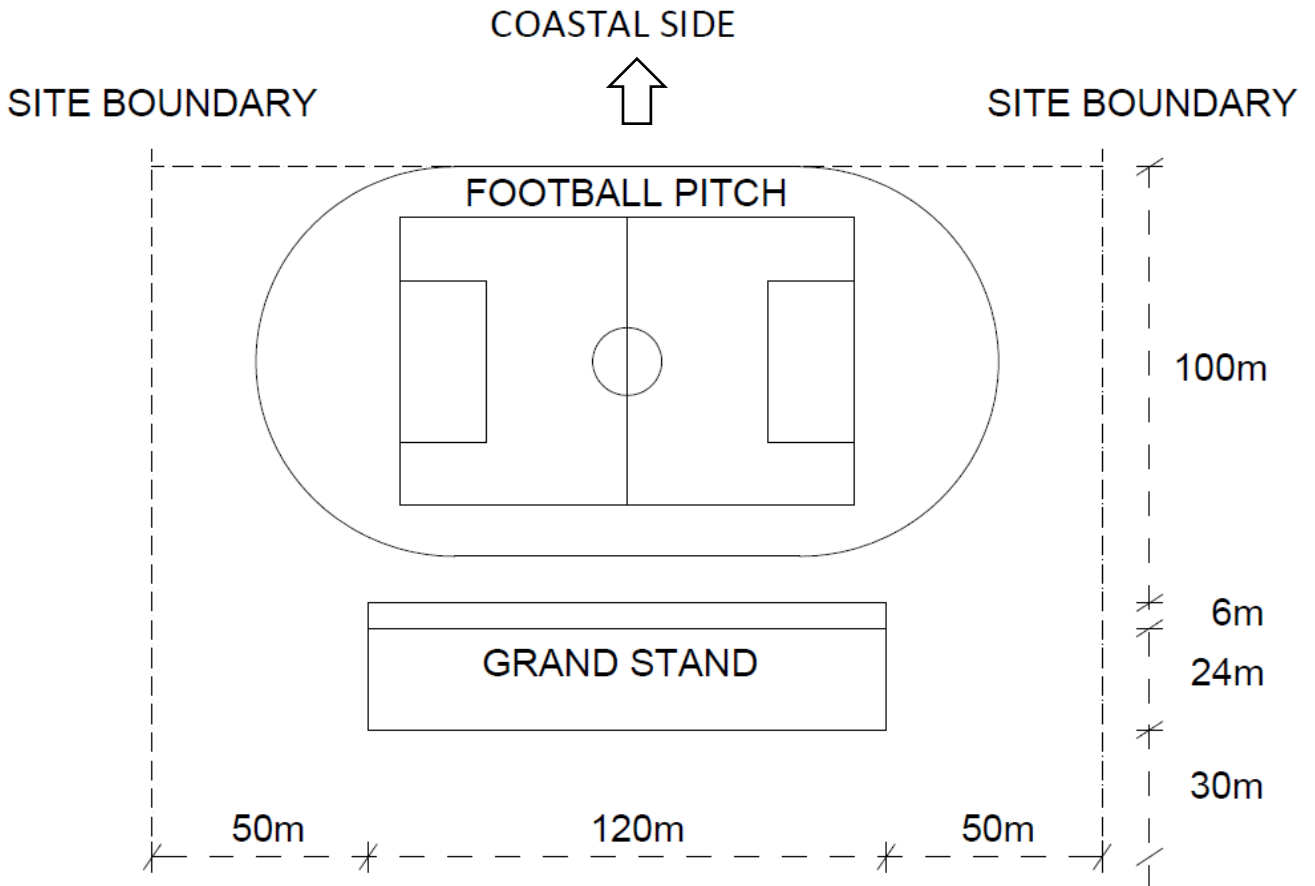

Figure Q5a KEY PLAN

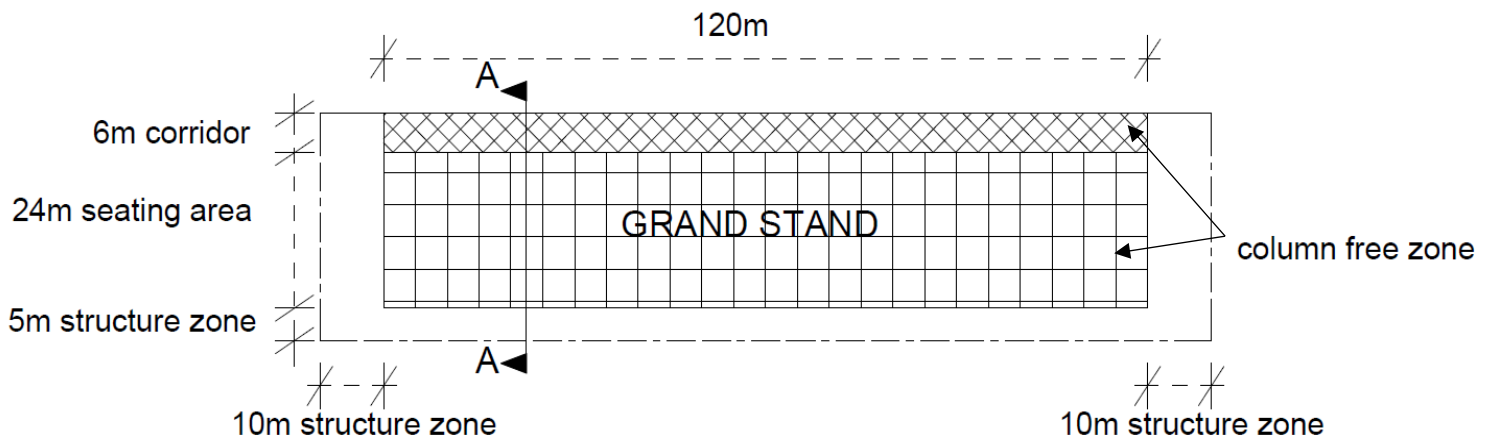

Figure Q5b PLAN VIEW

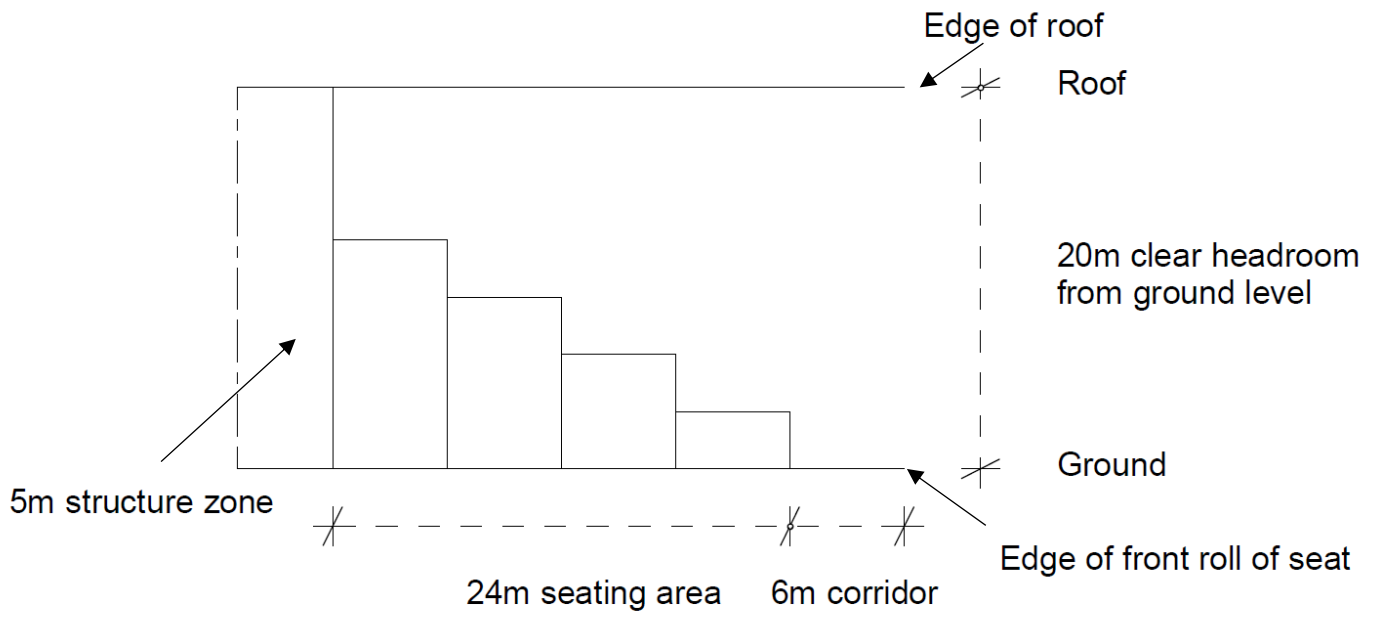

Figure Q5c SECTION A-A