



香港銅鑼灣記利佐治街1號金百利9字樓
9/F Island Beverley, No 1 Great George St, Causeway Bay, Hong Kong
電話Tel +852 2895 4446 傳真Fax +852 2577 7791
hkie-sec@hkie.org.hk www.hkie.org.hk

The HKIE Structural Examination – Written Examination 2019

Section 2: Design Questions (80% of the Written Examination)

Date: 29 November 2019 (Friday)
Time: 12:15 pm – 6:15 pm
(Duration: 6 hours)

Question Paper

Seat number:	
--------------	--

Answer ONE question only

Question 1 A Sports Stadium

Client's Requirements

The following client's requirements must be met:

1. A site located at a coastal area with ground level +10 mPD for construction of a fully enclosed stadium with greenery roof.
2. The footprint of the building is 80m in width and 100m in length. Clear headroom is 15m.
3. There is no height limitation except the maximum roof level above column free zone is 19.5m measured from the ground level.
4. Permanent audience seat zone of 5m width along 4 sides of the stadium.
5. Peripheral walls along East and West sides shall be covered by aluminum cladding panels with 8 exit doors on each side. The minimum center to center spacing between doors is 8m and the minimum door width and minimum door height are 6m and 8m respectively.
6. The North and South sides of the stadium shall have a minimum span clearance of 60m served as the column-free passage entrance.
7. No foundation (including the pile caps) shall be constructed within 1m below the existing ground level for the provision of underground utilities.
8. A minimum of 2 hours fire rating is required for all structural elements.

Imposed / Superimposed Dead Loads

Location	Imposed load (kPa)	Superimposed dead load (kPa)
Roof of stadium	4.0	2.0 (Greenery)
Ground floor of stadium	8.0	-
Audience seat	10.0	-

Wind Loads

9. The site is near the sea and wind code should be referred. The wind loads shall be in accordance with the Code of Practice on Wind Effects in Hong Kong 2004 or 2019.
10. For global stability design, the total uplift pressure coefficient for roof can be assumed as -2.2 which includes allowance for internal wind pressure. Appropriate value specified in other International Codes can also be adopted.
11. Natural lighting is to be provided by maximum 50% from the roof.

Site Conditions

12. Ground conditions as revealed by the ground investigation boreholes are:-

From existing ground level to 2m	Loose Fill, SPT N-value range from 5 to 10 [Category 4(d) soil] ^{Note 1}
2m to 10m	Medium dense sand with SPT N-values range from 11 to 30 [Category 4(c) soil] ^{Note 1}
10m to 40m	Dense to very dense completely decomposed granite with SPT N-values 50-200 [Category 4(b) to Category 4(a) soil] ^{Note 1}
Below 40m	Slightly to moderately decomposed (grade III or better) moderately strong granite with total core recovery greater than 85% [Category 1(c) rock] ^{Note 1}

Note 1: Categories of soil/rock refer to Table 2.1 of Code of Practice for Foundations 2017

13. Groundwater table is found at 1.0m below the existing ground level.

Omit from Consideration

14. Design of audience seats.
15. Design of cladding, windows, doors and skylights.
16. Design of all entrance and side exit doors.
17. Design of significant resonant dynamic effect.

Section A

- a. Prepare a design appraisal with appropriate sketches indicating two distinct and viable solutions for the proposed stadium including two viable foundation schemes. Indicate clearly the functional framing, load transfer and stability aspects of each scheme to meet all client's requirements. Identify the solution you recommend and give reasons for your choice.
(30 marks)
- b. Explain how the structure will resist wind load including detailed description of the structural wind loads and design assumptions. Prepare detailed wind load calculations for the proposed stadium.
(10 marks)

Section B

For the solution recommended in Section A:

- c. Prepare sufficient design calculations to establish the form and size of all the principal structural elements including the foundation.
(20 marks)
- d. Prepare framing plans, sections and elevations to show the dimensions, layout and disposition of the structural elements and critical details for cost estimation purposes.
(20 marks)
- e. Prepare a detailed method statement covering essential activities for the safe construction of the structure including foundation works and erection of roof.
(10 marks)
- f. Prepare a detailed construction program covering essential activities from commencement of foundation to completion of structural works.
(10 marks)

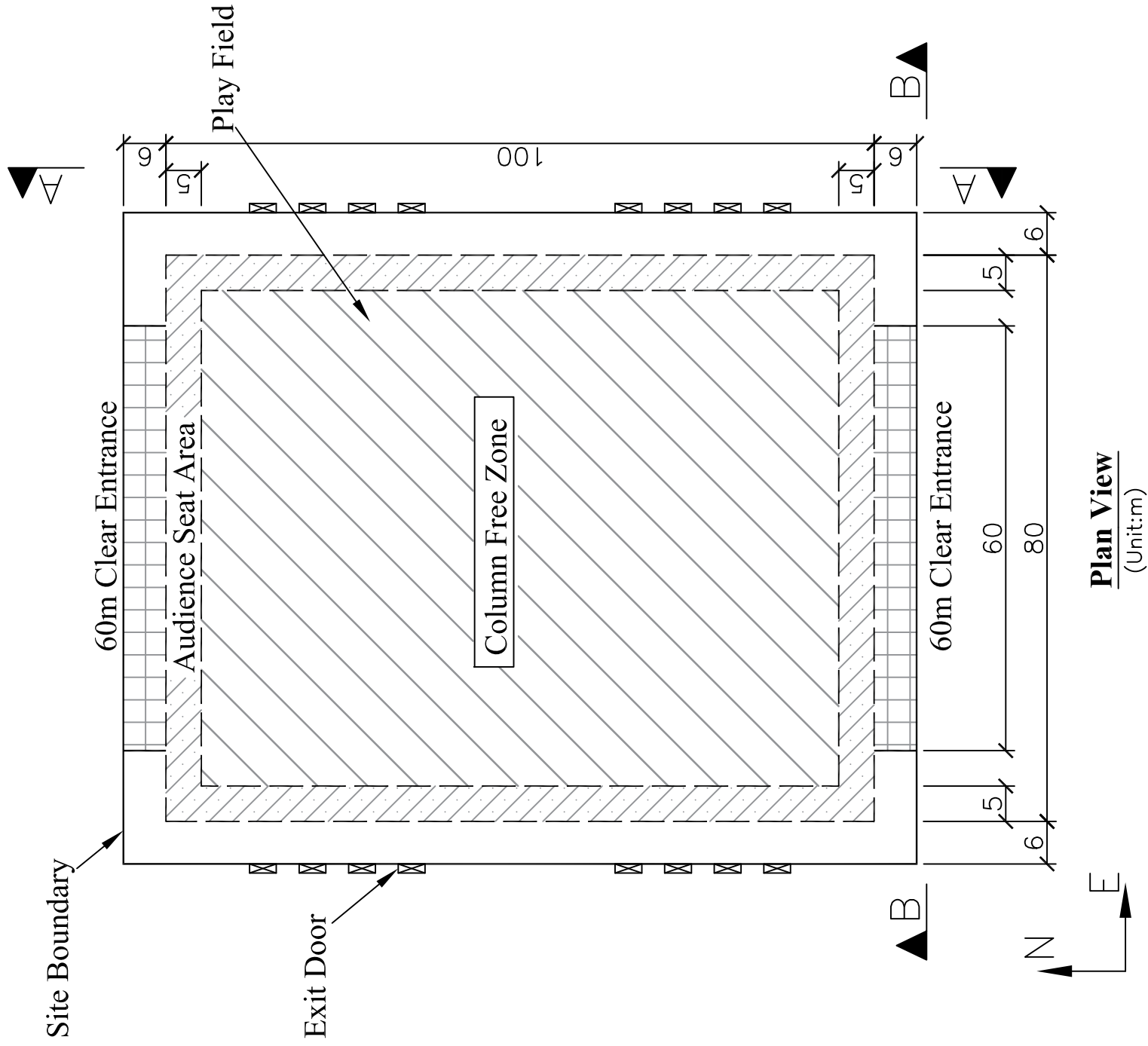
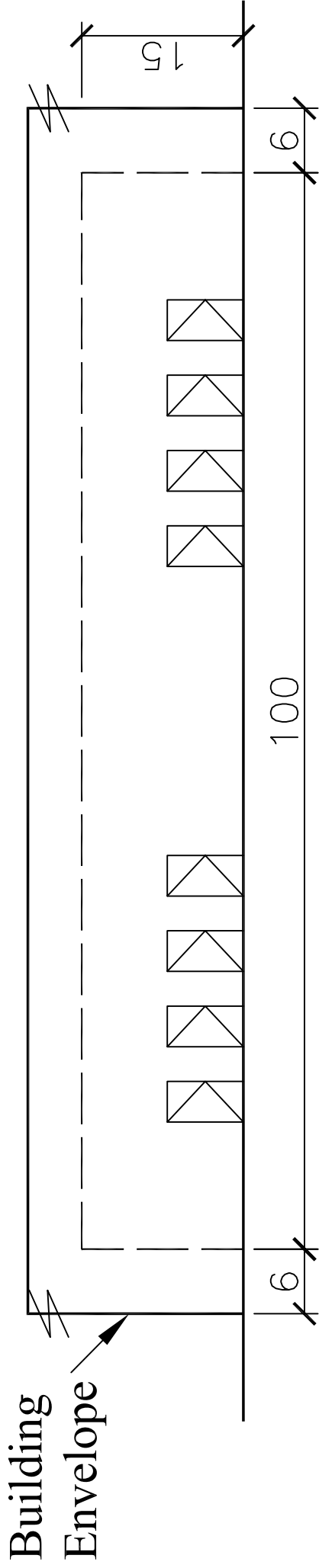
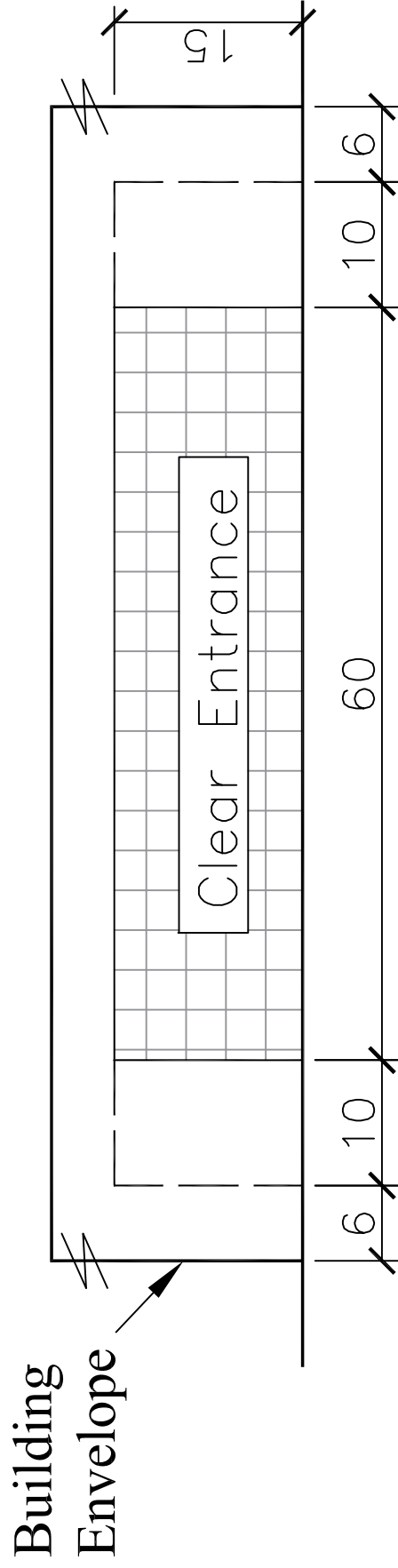

Figure Q1



Section A-A
(Unit:m)



Section B-B
(Unit:m)

Figure Q1

Question 2 Student Hostel Extension

Client's Requirements

The following client's requirements must be met:

1. A new 7-storey student hostel is to be built over an existing playground in Hong Kong to provide additional accommodation facilities for the University to meet the increasing demands.
2. The University likes to retain at least 4 badminton courts on the ground floor. The layout should retain the flexibility for converting to an open plan multi-purpose function hall, if required. Minimum column spacing should not be less than 6.5m center to center.
3. Each badminton court measures 6.1m x 13.4m on plan, with a minimum of 1.8m clear space surrounding all the outer lines of the courts. A clear height of 9.2m is required.
4. The minimum headroom clear of all structures, finishes and building services for 1/F to 6/F is 2.8m
5. A separation of 6m strip is required between the new hostel and the existing teaching facilities next door.
6. The ground floor is at +15.0mPD. There is a height restriction at +70.0mPD as per the Outline Zoning Plan.
7. Precast façade should be adopted for ease of construction.
8. The following finishes/services requires will apply:

Floor	Finishes	Floor to Floor Height	Building Services Zone
Underground	NA	NA	1.0m
Ground	Timber floor on 50mm screeding	12.0m	1.0 m
Typical floor (1/F- 6/F)	50mm screeding with Carpeting	4.0m	0.3 m
Roof	350mm thick (waterproofing & leveling screed) & 150mm insulation	NA	NA

9. A minimum 2-hour fire resistance rating is required for all structural elements.

Imposed Loads

10. The imposed loads shall be in accordance with the latest version of the Code of Practice for Dead and Imposed Loads in Hong Kong.
11. Superimposed deadload of 15kPa should be allowed for the Sky Garden at 5/F.

Wind Loads

12. The wind loads shall be in accordance with the Code of Practice on Wind Effects in Hong Kong 2004 or 2019.

Site Conditions

13. The site is located near a 45-degree slope .
14. Ground Conditions:

Ground to +10.0mPD	Loose fill
+0mPD to +10mPD	Sand/gravel, SPT N-value = 25
-30mPD to +0mPD	Sand/gravel, SPT N-value = 50 - 80
Below -30mPD	Slightly to moderately decomposed bedrock of Grade 1(c) or better
Designated Ground Water Level	+8.0mPD

15. Site Specific Conditions:

- a. Existing teaching facilities building was built in the early 70s with shallow footing foundation.
- b. A 2x2m culvert is running in the Drainage Reserve and must remain operation throughout the construction.
- c. University and EPD Noise restrictions requirements are to be observed. No percussive piling is allowed during the normal class sessions and examination period between April and June.

16. Special Consideration. No foundation nor substructure (pile caps, ground beams and suspended ground slabs) works should fall within the drainage reserve area.

Omit from Consideration

17. Design of staircases.
18. Detailed layout and design of the non-structural elements inside the service cores.
19. Precast façade & window systems.
20. Design of protective barriers.

Section A

- a. Prepare a design appraisal with appropriate sketches indicating two distinct and viable solutions for the proposed hostel including two viable foundation schemes. Indicate clearly the functional framing, load transfer and stability aspects of each scheme to meet all client's requirements. Identify the solution you recommend and give reasons for your choice.

(30 marks)

- b. Explain how the structure will resist wind load including detailed description of the structural wind loads and design assumptions. Prepare detailed wind load calculations for the proposed hostel.

(10 marks)

Section B

For the solution recommended in Section A:

- c. Prepare sufficient design calculations to establish the form and size of all the principal structural elements including the foundation.

(25 marks)

- d. Prepare framing plans, sections and elevations to show the dimensions, layout and disposition of the structural elements and critical details for cost estimation purposes.

(25 marks)

- e. Prepare a detailed method statement covering essential activities for the safe construction of the hostel including foundation works.

(5 marks)

- f. Prepare a detailed construction program covering essential activities from commencement of foundation to completion of structural works.

(5 marks)

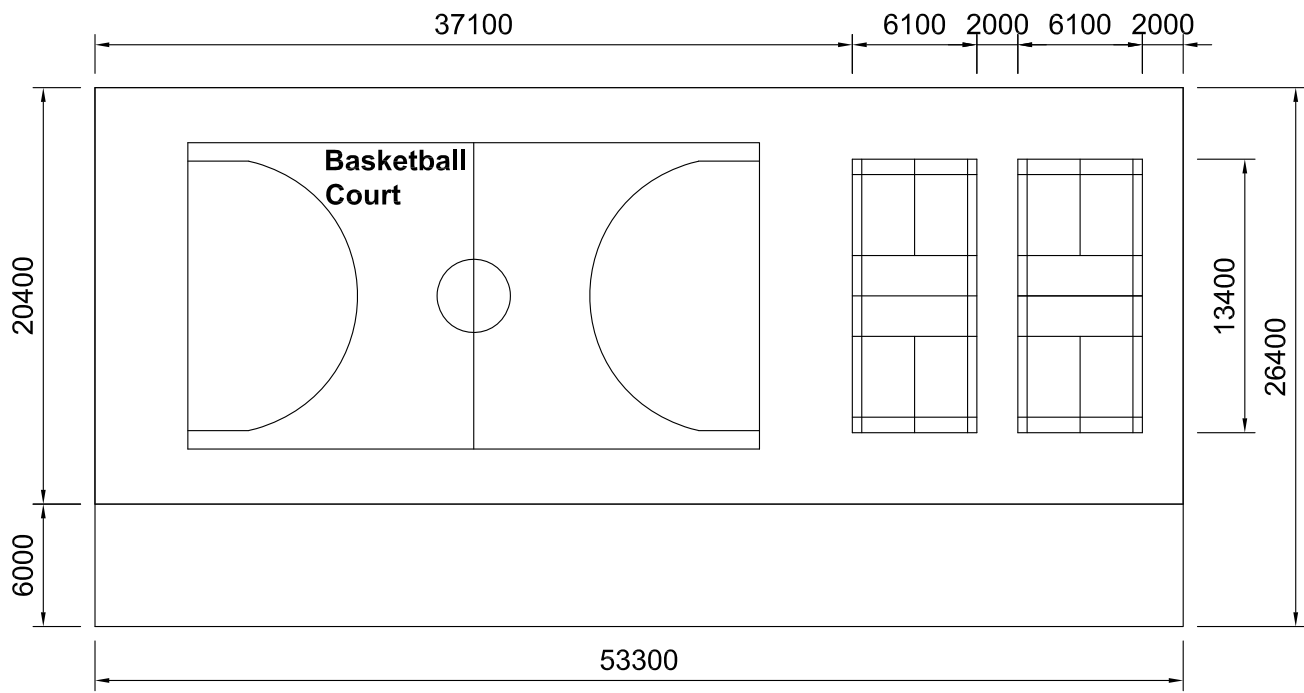

Existing Site Plan

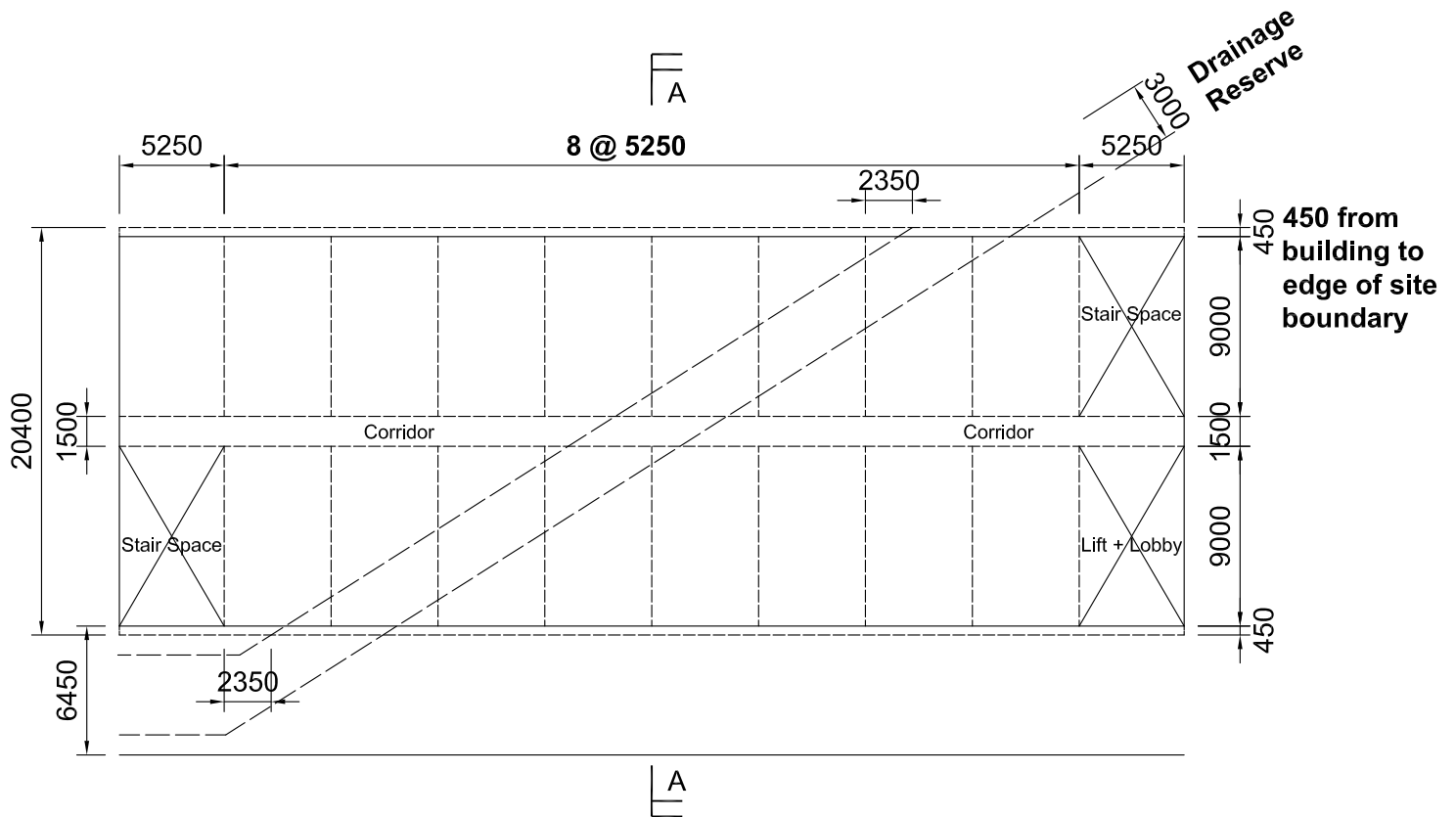

New Hostel Layout Plan (1/F - 4/F)

Note: All dimensions are in Millimeters (mm)

Figure Q2

Question 3 Workshop

Client's Requirements

The following client's requirements must be met:

1. A workshop building is to be constructed within the developed area of Hong Kong.
2. The proposed use of workshop building with the minimum headroom requirements and fire resistance rating is listed as follows:

Floor Mark	Usage	Minimum Clear Headroom* (m)	Fire Resistance Rating	Finishes & E/M Services Zone (m)
3/F – 20/F	Workshop	3.3	2 hours	0.3
2/F	Switch Room	3.5	2 hours	0.5
1/F	Transformer Room	3.5	2 hours	0.5
G/F – 2/F	Shop/ Workshop	3.5	2 hours	0.5
G/F	Loading/ Unloading/Driveway	4.5	1 hour	0
B/F	Car park	2.5	4 hours	0.5

* The minimum clear headroom is the floor height clear of all structures, finishes and building services.

3. The restrictions on the location of vertical structural elements are as follows:

Floor Mark	Area	Restrictions
G/F – 20/F	Shop/Workshop/ Switch Room/ Transformer Room	<ul style="list-style-type: none"> - Minimum spacing of internal columns is 9.0m centres. - No restriction on spacing between the internal columns to peripheral wall and/or column if any.
G/F – 2/F	Transformer Delivery Route	<ul style="list-style-type: none"> - Not permitted inside the Transformer Delivery Route area.
B/F – G/F	Driveway/Car lift	<ul style="list-style-type: none"> - Not permitted inside the driveway and car lift.
G/F	Loading/Unloading	<ul style="list-style-type: none"> - Minimum spacing of internal columns is 9.0m centres. - No restriction on spacing between the internal columns to peripheral wall and/or column if any
B/F	Car Parking	<ul style="list-style-type: none"> - Minimum spacing of internal columns is 7.5m centres.

4. The main roof structure above tower and flat roof structure at 3/F shall not be inverted.
5. No hanger structure is permitted.
6. For cantilever structure (if any), the maximum cantilever span shall be less than 4.0m from centre of support.

Imposed Loads

7. The imposed load for workshop shall be Class 5 according to table 3.2 of the Code of Practice for Dead and Imposed Loads. The specific use shall be “Workshops for light weight loads”.

Wind Loads

8. The wind loads shall be in accordance with the Code of Practice on Wind Effects in Hong Kong 2004 or 2019.

Site Conditions

9. Abutting the eastern boundary of the site is a 3-storey pre-war brick building with shallow footing foundation. Adjoining the western boundary of the site is a 20-storey reinforced building on pile foundation.

10. Ground conditions:

From +6mPD to -10mPD	Lose Fill, SPT average N-value = 10 [Category 4(d)] ^{Note 1}
From -10mPD to -22mPD	Medium dense sand, SPT average N-value = 30 [Category 4(c)] ^{Note 1}
From -22mPD to -34mPD	Completely decomposed granite, SPT N-value > 200 [Category 3] ^{Note 1}
Below -34mPD	Moderately decomposed granite with total core recovery greater than 85% [Category 1(c) rock] ^{Note 1}

Note 1: Categories of soil/rock refer to Table 2.1 of Code of Practice for Foundation 2017

11. The highest possible groundwater level is at +6mPD.

Omit from Consideration

12. Detailed layout and design of the structure inside the service core.

Section A

- a. Prepare a design appraisal with appropriate sketches including two distinct and viable solutions for the proposed workshop building including two viable foundation schemes. Indicate clearly the functional framing, load transfer and stability aspects of each scheme to meet all client's requirements. Identify the solution you recommend and give reasons for your choice.

(30 marks)

- b. Explain how the structure will resist wind load including detailed description of the structural wind loads and design assumptions. Prepare detailed wind load calculations and stability checking for the proposed workshop building.

(10 marks)

Section B

For the solution recommended in Section A:

- c. Prepare design calculations to establish the form and size of all principal structural elements for superstructure from G/F to 3/F, including transfer (if any) and critical structures.

(14 marks)

- d. Prepare dimensional framing plans for G/F to typical floor including transfer (if any) and critical structures.

(20 marks)

- e. Prepare structural details for the principal structural elements from G/F to 3/F, including transfer (if any) and critical structures, for cost estimation purpose.

(14 marks)

- f. Prepare the design calculation for the building foundation.

(4 marks)

- g. Prepare a preliminary foundation layout plan.

(4 marks)

- h. Prepare an outline construction program covering essential activities from commencement of foundation to the completion of structural works.

(4 marks)

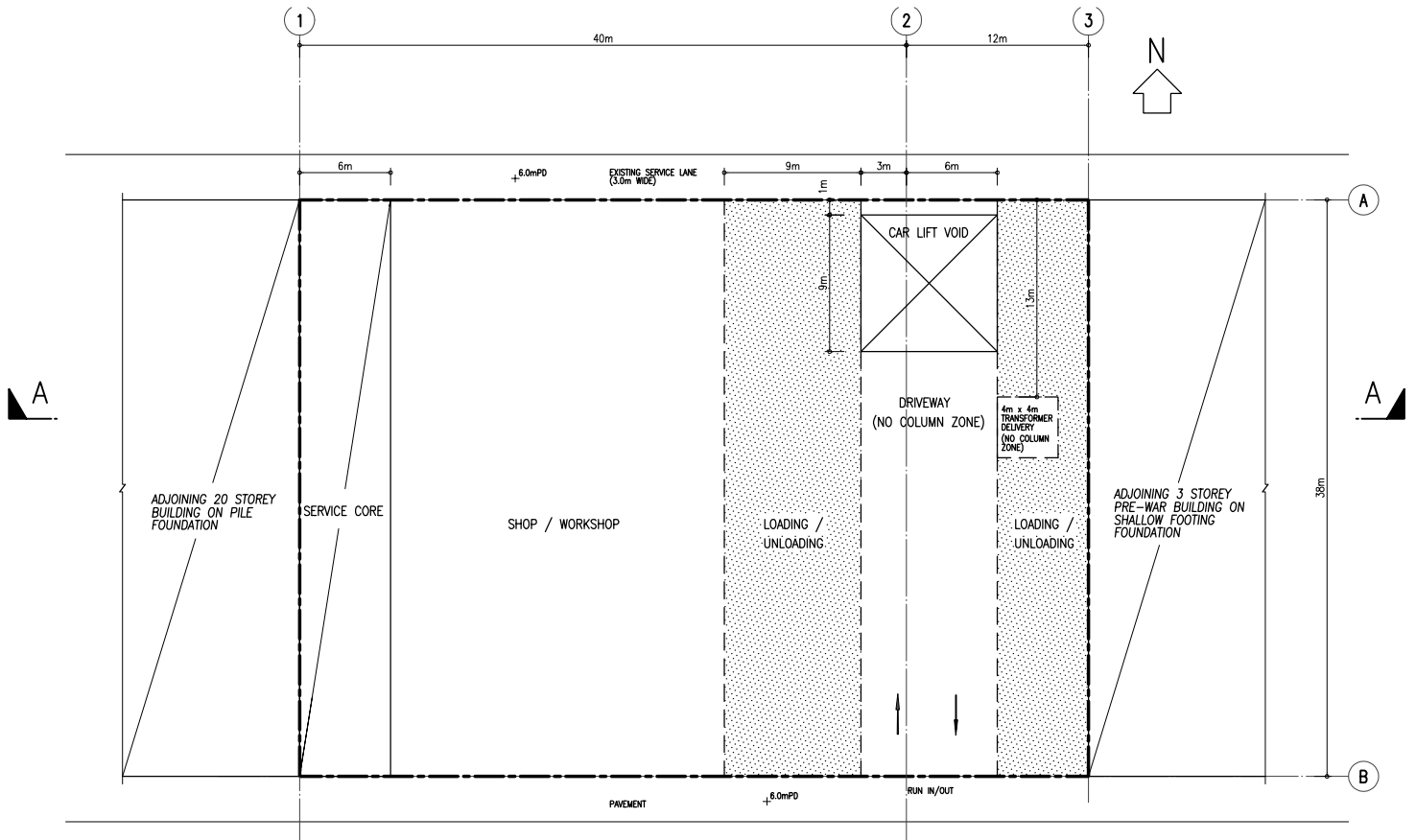

G/F PLAN

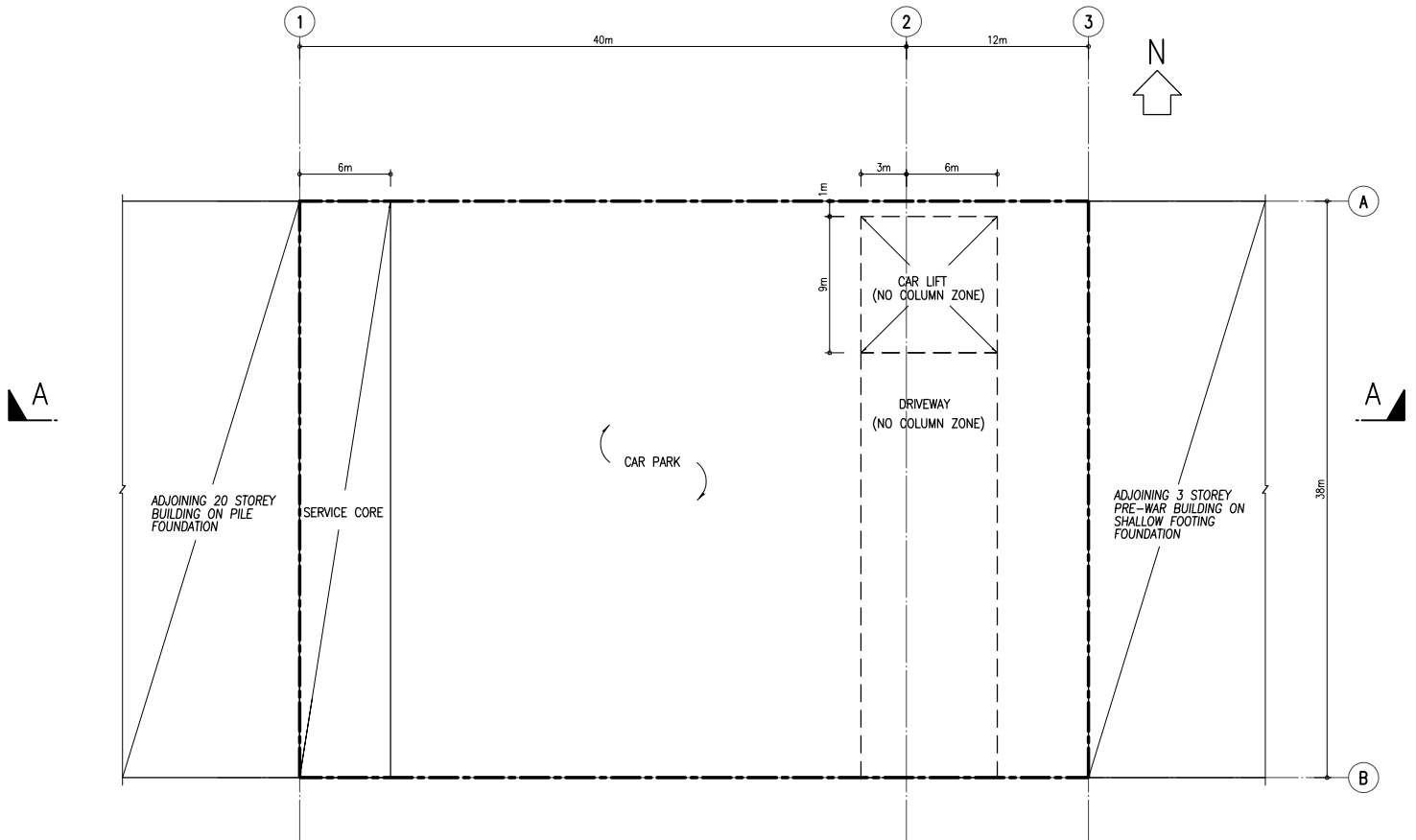
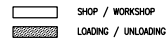

B/F PLAN

Figure Q3

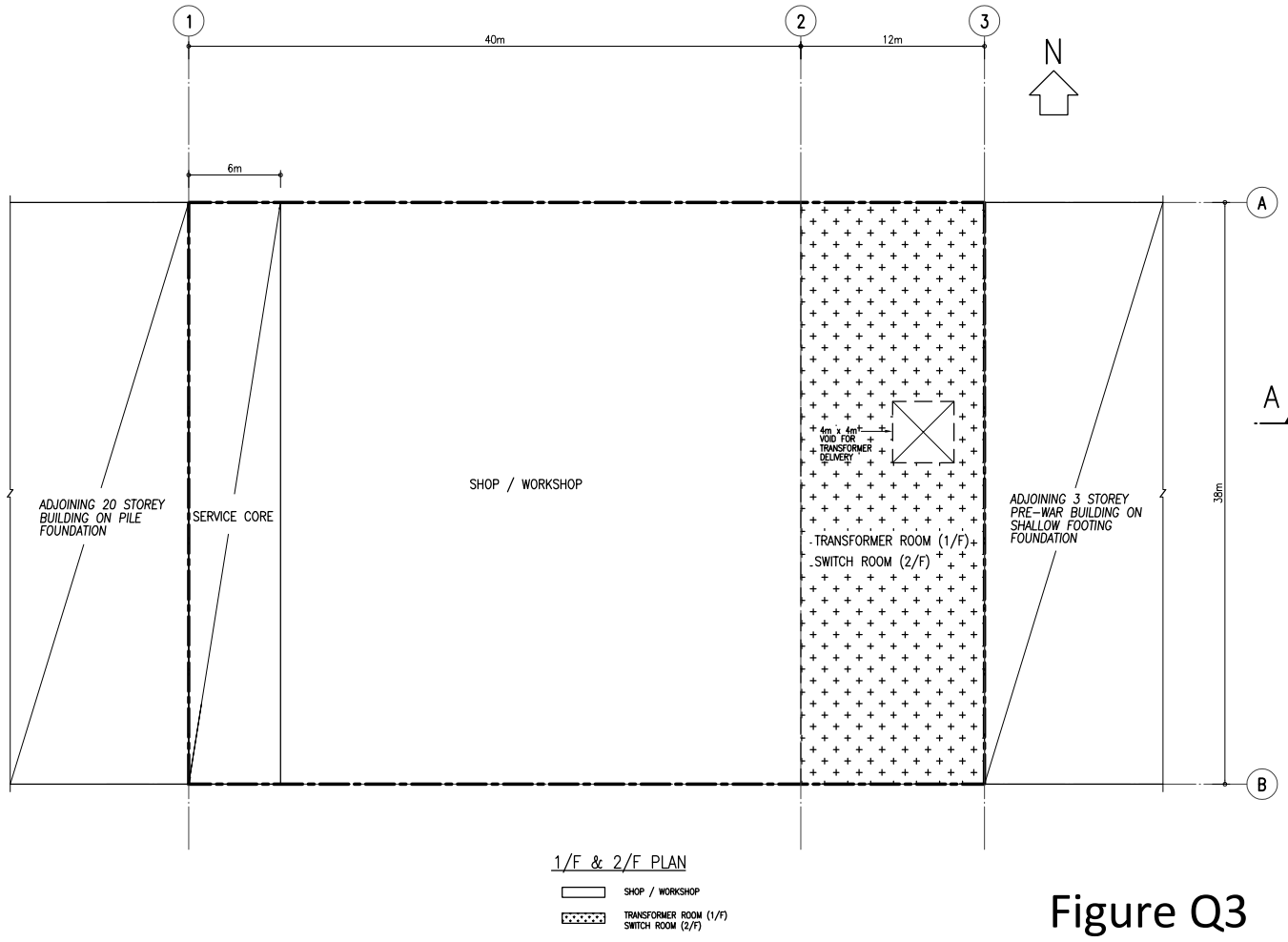
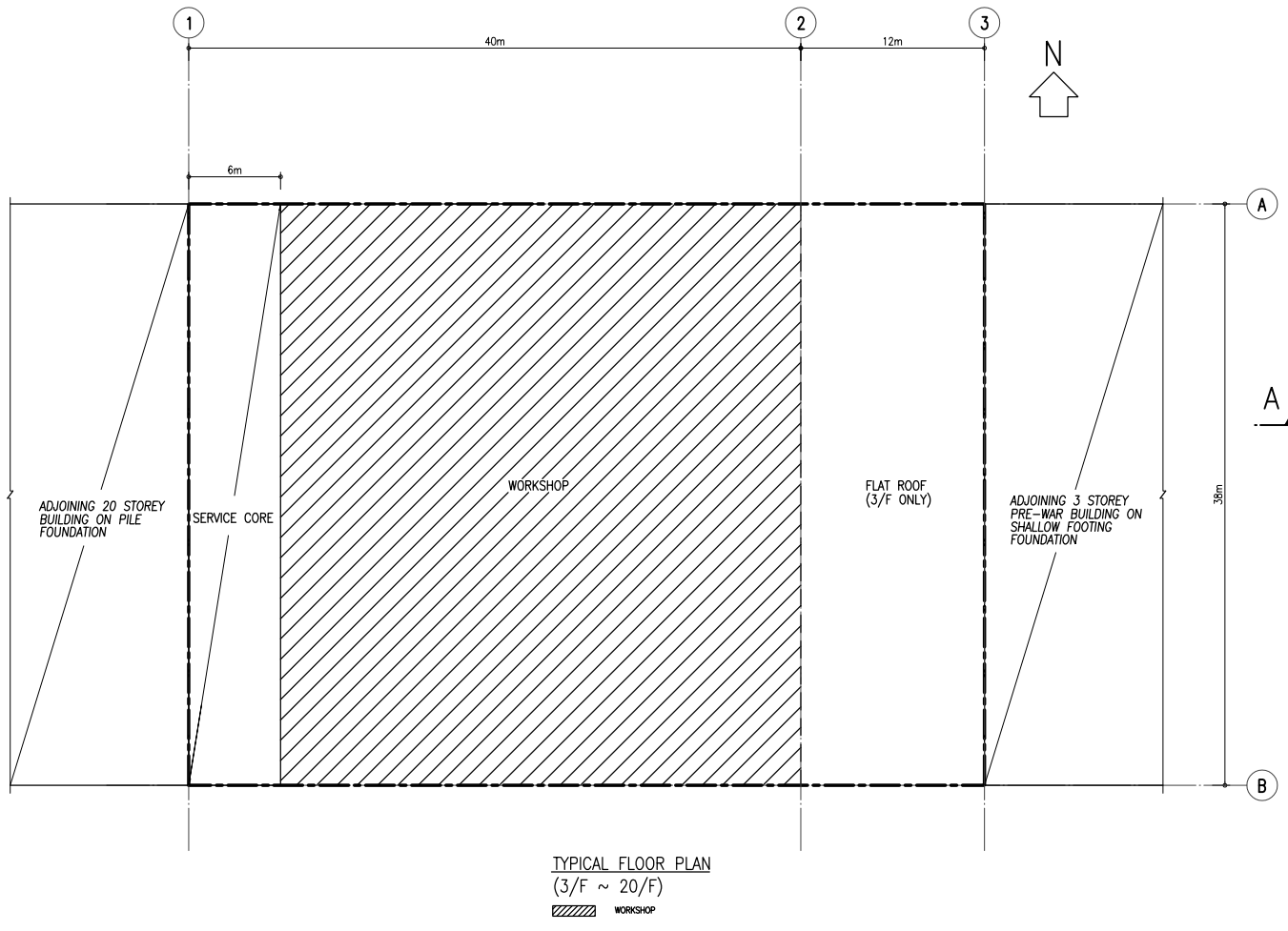
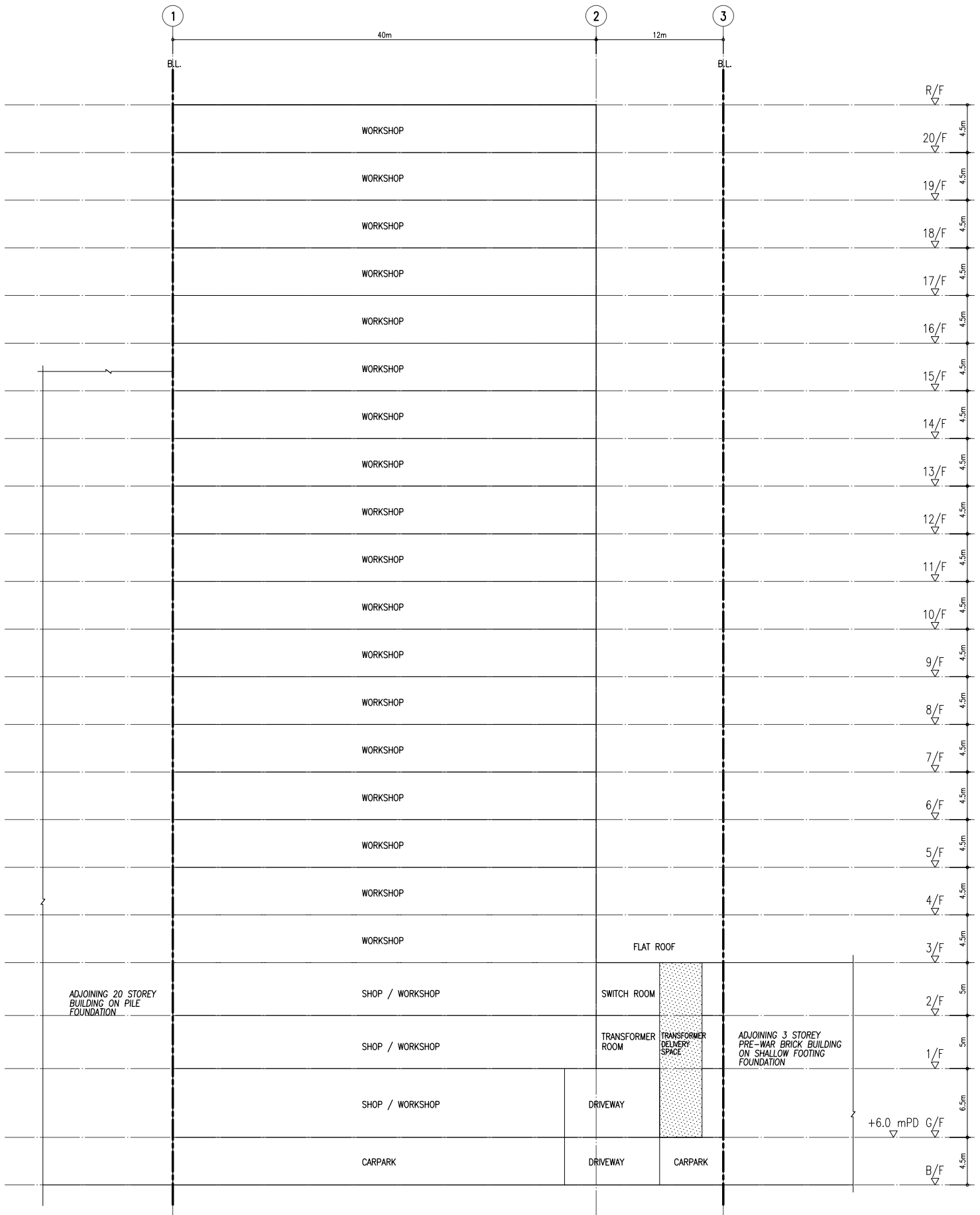

Figure Q3



SECTION A - A

Figure Q3

Question 4 Pedestrian/Cycle Bridge

Client's Requirements

The following client's requirements must be met:

1. A proposed bridge carrying a footpath and cycle track is to be built over an existing railway line, ground level pedestrian/cycle access and utilities zone with staircases and straight/circular ramp connecting the two areas. See Figure Q4.
2. The site is located near an international airport. No permanent structures are to be placed higher than 12.0m above datum level and abutments are to be placed at a position as shown on Section A-A in Figure Q4.
3. The Railway Line needs to be opened to traffic at all times and the utilities zone needs to be protected and maintained throughout the construction. Possession over railway line can be obtained between 12.00 midnight to 6.00am on each Sunday per week during construction.
4. The design of the structure should have a minimum longitudinal gradient of 2.0% fall to allow for drainage. Concrete high containment barrier to be provided over railway line as indicated.
5. The minimum requirements on clear headroom over railway, footpaths, utilities and maintenance zone are as follows:

<u>Location</u>	<u>Min. Clear Headroom (m)</u>
Railway Line	7.0
Footpaths/cycle track	5.0
Utilities and maintenance zone	5.5

6. The construction is planned to complete in two and a half years.

Design Requirements

7. The structural design shall be in accordance with the latest version of the Structures Design Manual for Highways and Railways published by the Highways Department of the HKSAR Government.

Imposed Loads

8. The imposed loads and highway loadings shall be in accordance with the latest version of the Structures Design Manual for Highways and Railways.

Wind Loads

9. The wind loads shall be in accordance with the requirements in the latest version of the Structures Design Manual for Highways and Railways.

Site Conditions

10. The site is located at rural open area with Degree 3 of exposure to wind.
11. Ground conditions are:

Ground level – 2m	Loose Fill, SPT N-value = 0 – 5 [Category 4(d)] ^{Note 1}
2m – 7m	Medium dense soil, SPT N-value = 10 – 30 [Category 4(c)] ^{Note 1}
7m – 20m	Very dense soil, SPT N-value >50 [Category 4(d)] ^{Note 1}
20m and below	Moderately decomposed granite with total core recovery > 85% [Category 1(c) rock] ^{Note 1}

Groundwater is encountered at 3.0m below ground level.

Note 1: Categories of soil/rock refer to Table 2.1 of Code of Practice for Foundation 2017

Omit from Consideration

12. Design calculations for both staircases, both abutments and containment barrier.
13. Detailed layout of both staircases and both abutments.

Section A

- a. Prepare a design appraisal with appropriate sketches indicating two distinct and viable solutions for the span of the proposed bridge over the service corridor (excluding all ramps and staircases) including two viable foundation schemes. Indicate clearly the functional framing, load transfer and stability aspects of each scheme to meet all client's requirements. Identify the solution you recommend and give reasons for your choice.

(30 marks)

- b. Explain how the structure will resist wind load including detailed description of the structural wind loads and design assumptions. Prepare detailed wind load calculations for the proposed bridge.

(10 marks)

Section B

For the solution recommended in Section A:

- c. Prepare sufficient design calculations to establish the form and size of all the principal structural elements including the foundation.

(20 marks)

- d. Prepare framing plans, sections and elevations to show the dimensions, layout and disposition of the structural elements and critical details for cost estimation purposes.

(20 marks)

- e. Prepare a detailed method statement covering essential activities for the safe construction of the bridge including foundation works.

(10 marks)

- f. Prepare a detailed construction program covering essential activities from commencement of foundation to completion of structural works.

(10 marks)

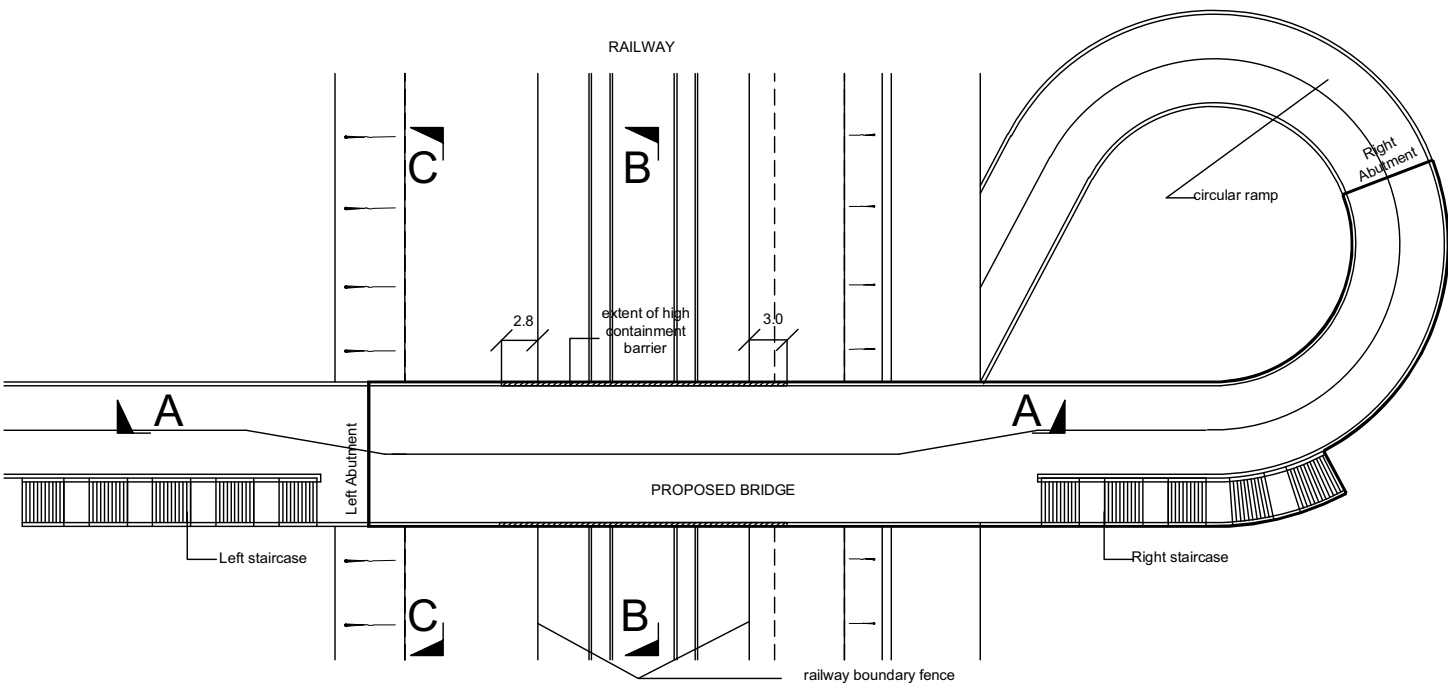

PLAN

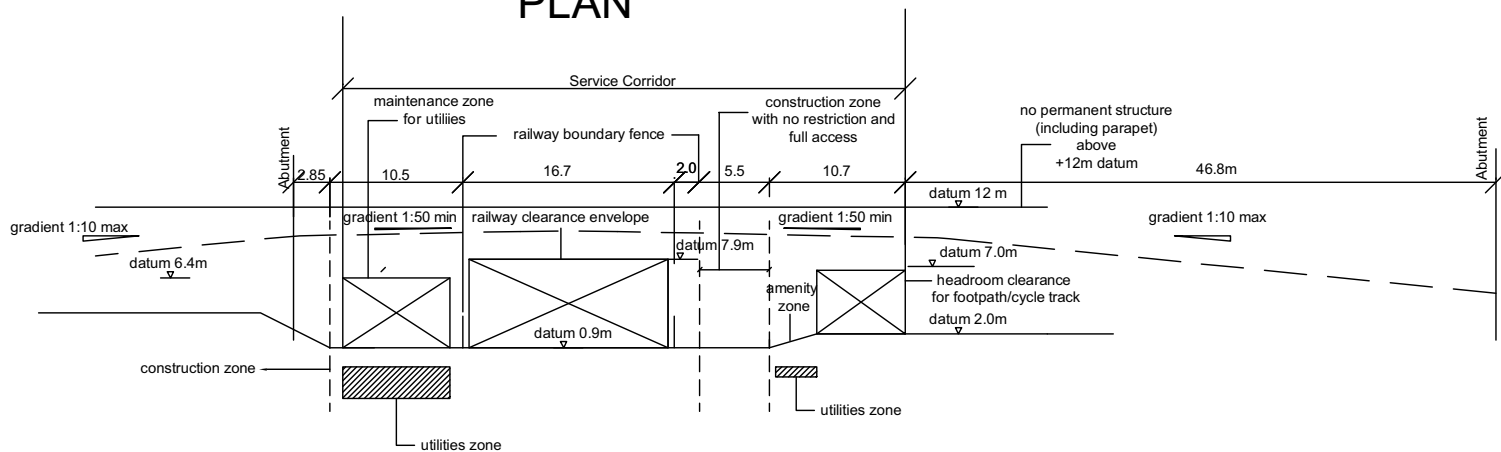

SECTION A-A

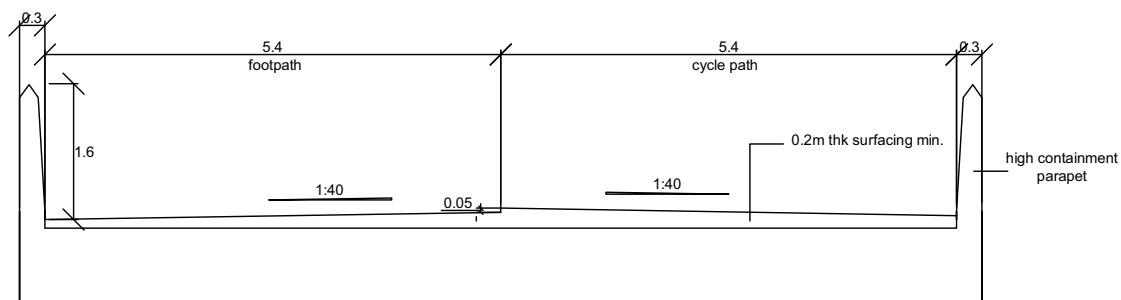

SECTION B-B

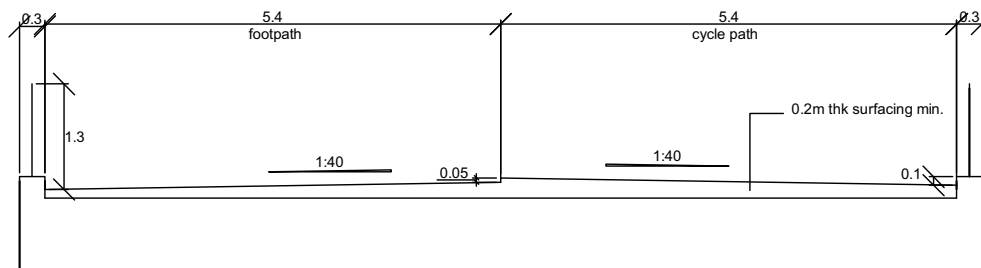

SECTION C-C

Figure Q4

Note: All units are in metre