



香港銅鑼灣記利佐治街1號金百利9字樓  
9/F Island Beverley, No 1 Great George St, Causeway Bay, Hong Kong  
電話Tel +852 2895 4446 傳真Fax +852 2577 7791  
hkie-sec@hkie.org.hk www.hkie.org.hk

## **The HKIE Structural Examination – Written Examination 2017**

### **Section 2: Design Questions (80% of the Written Examination)**

Date: 5 December 2017 (Tuesday)  
Time: 12:00 nn – 06:00 pm  
(Duration: 6 hours)

**Question Paper**

**Answer ONE question only**

## **Question 1      Hotel Annex**

### **Client's Requirements**

The following client's requirements must be met:

1. A hotel owner plans to build a ballroom cum theatre annex to its existing hotel. The development is to be fast-track, and the construction must have the least noise impact to the existing hotel guests. See figure Q1.
2. The ballroom will have an internal clear dimension of 90m x 55m while the theatre on its side will have an internal unobstructed dimension of 35m x 55m.
3. The ballroom should have a clear height of 11.5m, and there should be unobstructed sea view at the western end of the ballroom.
4. The theatre will have a clear headroom of 13m.
5. All other locations should have minimum clear headroom of 3.5m.
6. There will be a basement under the theatre area to house Back Of House (BOH), building services, equipment for stage special operation, staff meeting rooms and food storage for ballroom kitchen.
7. The ballroom floor will be finished with high end marbles and tiles, floor settlement is to be limited.
8. A minimum of 2-hour fire resistance rating is required for all elements of construction.
9. No structure or foundation is to be built beyond the building boundary.
10. Columns are to be spaced at not less than 10m centre to centre.

## Imposed Loads

11. Roof Accessible
- Ballroom To satisfy functional requirement, the ceiling structure of the ballroom must be able to support an additional concentrated load of 25kN at any location.
- Theatre To satisfy functional requirement, the bottom member of the ceiling structure over the stage area of the theatre must be able to support additional loadings of 2kN/m<sup>2</sup> plus a concentrated load of 5kN at any location.
- The theatre floor has to be able to support seating platform of 10kN/m<sup>2</sup>.

## Site Conditions

12. The annex site is located south of the existing hotel complex. The hotel is on piles and has 2 levels of basements. Along the south side of the annex site is a major city road where key utilities including water, gas, sewerage, fibre optic cables etc. are located and are within 2 metres from the site boundary.

13. Ground conditions are:

Ground level – 8m	Fill comprising of loose silty fine to medium sand, SPT average N-value = 10
8m – 18m	Marine Deposit comprising dark grey clay, SPT average N-value = 5
18m – 38m	Alluvial Clay comprising of brown sandy silty clay, SPT average N-value = 30
38m – 60m	CDG comprising of completely decomposed granite, SPT N-value > 200
60m and below	MDG comprising of moderately decomposed granite, TCR > 50%

Ground water is encountered at 1m below ground level.

## Omit from Consideration

14. Design of lift core and staircases.

## **Section A**

- a. Prepare a design appraisal with appropriate sketches indicating two distinct and viable solutions for the proposed ballroom cum theatre annex including two viable foundation schemes. Indicate clearly the functional framing, load transfer and stability aspects of each scheme to meet all client's requirements. Identify the solution you recommend and give reasons for your choice.

**(40 marks)**

## **Section B**

For the solution recommended in Section A:

- b. Prepare sufficient design calculations to establish the form and size of all the principal structural elements including the foundation.

**(20 marks)**

- c. Prepare framing plans, sections and elevations to show the dimensions, layout and disposition of the structural elements and critical details for estimating purposes.

**(20 marks)**

- d. Prepare a detailed construction program covering essential activities from commencement of foundation to completion of structural works.

**(10 marks)**

- e. At the early stage of the construction, the client enquires about possibility of turning the roof into a green roof. Prepare a report to client detailing the implications to the design and the construction of the development.

**(10 marks)**

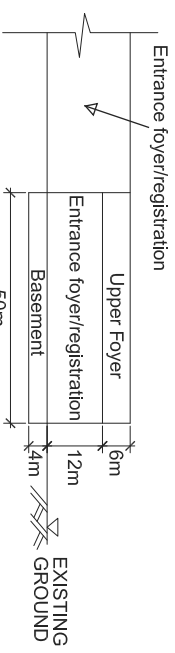
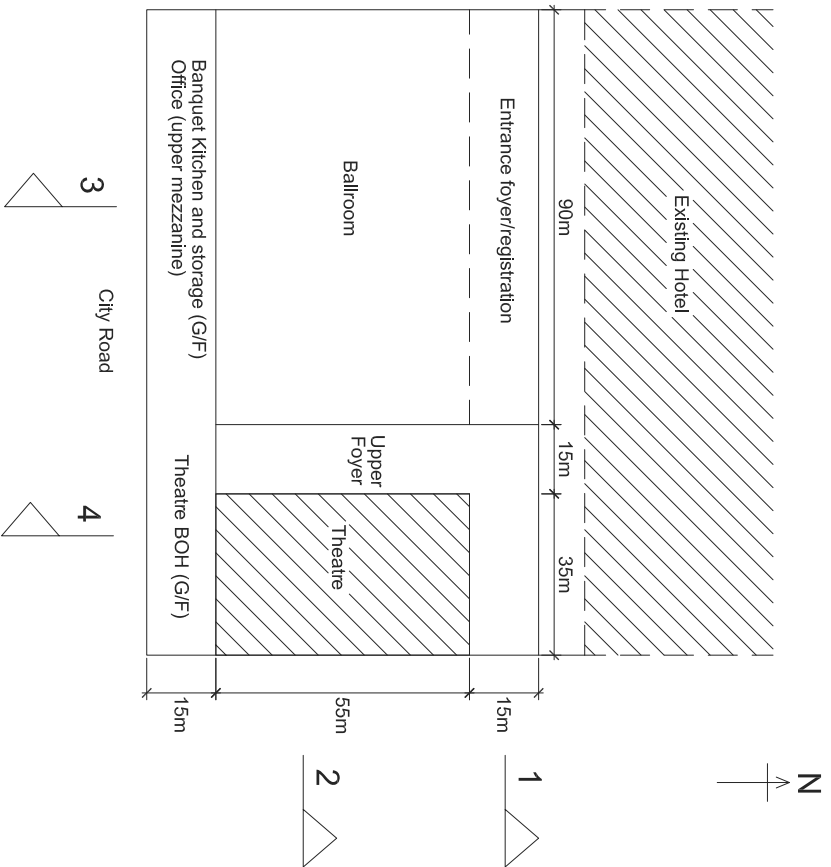

Section 1

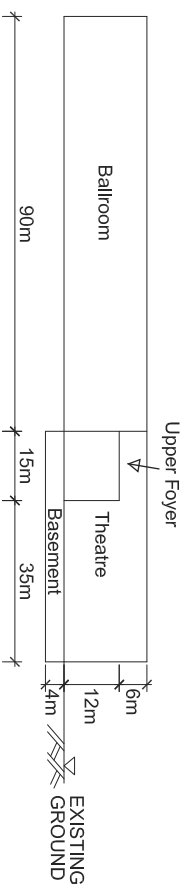

Section 2

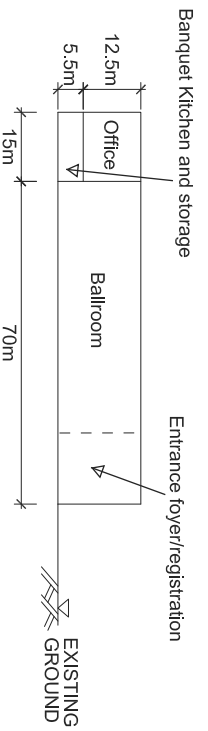

Section 3

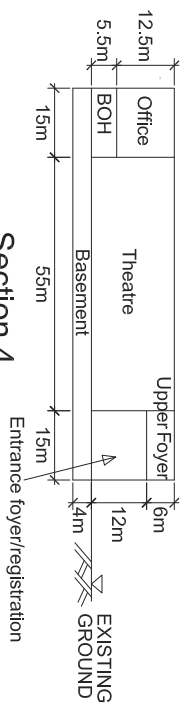

Section 4

Figure Q1

## Question 2      Shopping Center

### Client's Requirements

The following client's requirements must be met:

1. A four storey shopping center, in an open site, is to be constructed in Tsim Sha Tsui, Kowloon. See figure Q2.
2. Minimum column spacing (center to center) is 8m.
3. No column is allowed at the ground floor entrance lobby.
4. 250mm curtain wall is to be allowed at the perimeter of the building to allow for natural lighting.
5. Minimum requirements on clear headroom (clear height of all structure, finishes and building services) are as follows:

<u>Floor</u>	<u>Use</u>	<u>Min. Headroom (m)</u>	<u>Finishes &amp; Services Zone (m)</u>
All	Shopping center	5.0	0.3

6. A minimum 2-hour fire resistance rating is required for all structural elements.

### Imposed Loads

7. The imposed loads shall be in accordance with the latest version of the Hong Kong Code of Practice for Dead and Imposed Loads.

### Wind Loads

8. The wind loads shall be in accordance with the Code of Practice on Wind Effects in Hong Kong 2004.

## Site Conditions

9. The site is located in Tsim Sha Tsui, Kowloon at a datum level of about +4.5mPD.

10. Ground conditions are:

Ground level – 2m	Alluvium, SPT N-value = 100
2m – 15m	Highly decomposed granite, SPT N-value greater than 300
15m and below	Slightly to moderately decomposed moderately strong granite or volcanic rock of material weathering grade III or better with allowable bearing pressure of 5,000Kpa

Ground water is encountered at 0.2m below ground level.

## Omit from Consideration

11. Design of the skylight on roof floor

## **Section A**

- a. Prepare a design appraisal with appropriate sketches indicating two distinct and viable solutions for the proposed shopping center including two viable foundation schemes. Indicate clearly the functional framing, load transfer and stability aspects of each scheme to meet all client's requirements. Identify the solution you recommend and give reasons for your choice.

**(30 marks)**

- b. Explain how the building structure will resist wind load including detailed description of the structural wind loads and design assumption. Prepare a detailed wind load calculation for the proposed shopping center.

**(10 marks)**

## **Section B**

For the solution recommended in Section A:

- c. Prepare sufficient design calculations to establish the form and size of all the principal structural elements including the foundation.

**(20 marks)**

- d. Prepare framing plans and a sectional plan in East-West direction to show the dimensions, layout and disposition of the structural elements and critical details for estimating purposes.

**(20 marks)**

- e. Prepare a detailed method statement covering essential activities for the safe construction of the building including excavation / lateral support and foundation works but excluding curtain wall installation.

**(10 marks)**

- f. Prepare a detailed construction program covering essential activities from commencement of foundation to completion of structural works.

**(10 marks)**

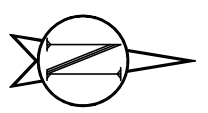
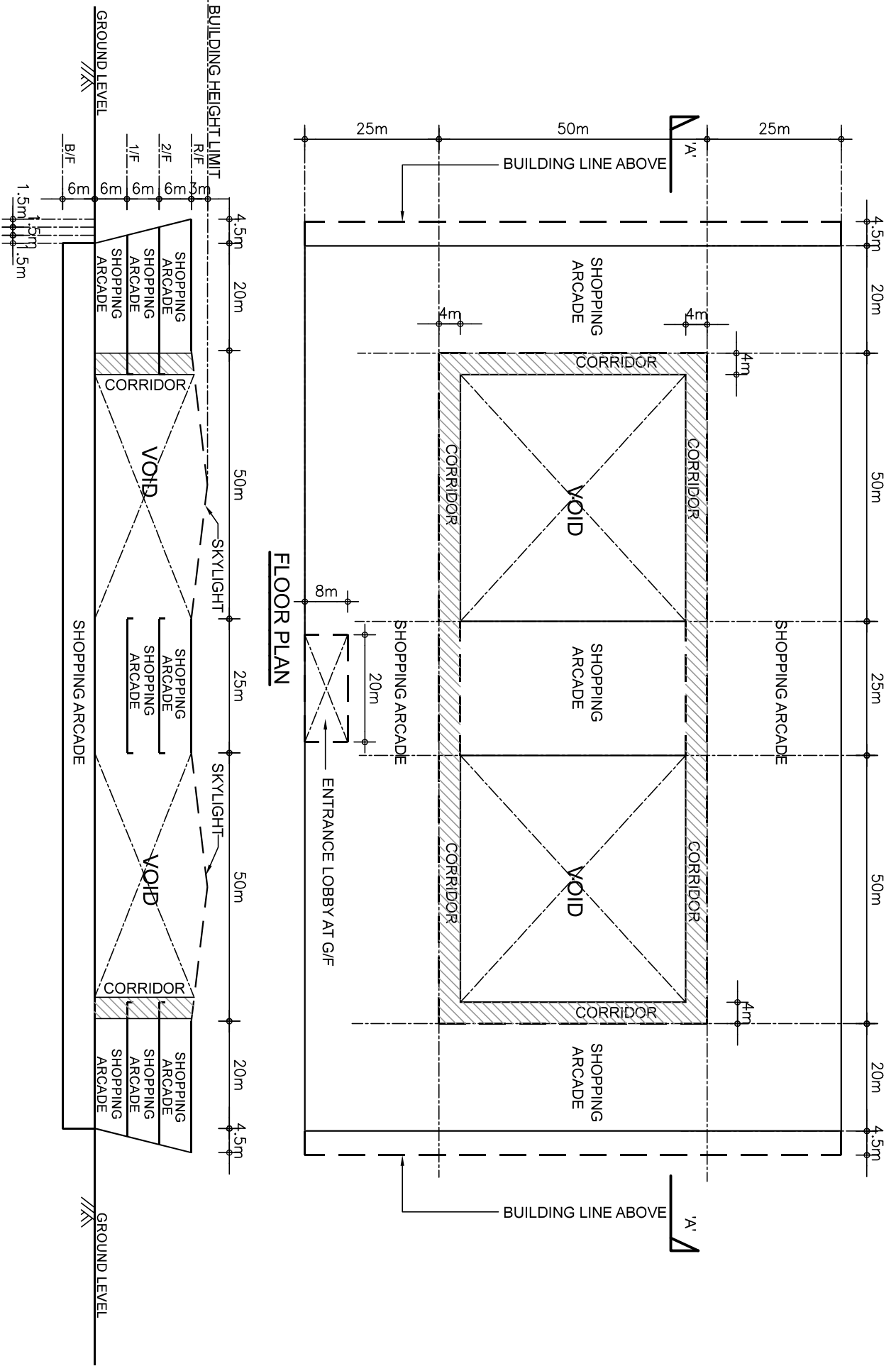

**SECTION 'A-A'**

**Figure Q2**

## Question 3 Industrial Building

### Client's Requirements

The following client's requirements must be met:

1. An industrial building is to be constructed within the developed area of Hong Kong. See figure Q3.
2. The proposed use of industrial building with the minimum headroom requirements and fire resistance rating is listed as follows:

Floor Mark	Usage	Minimum Clear Headroom* (m)	Fire Resistance Rating	Finishes & E/M Services Zone (m)
2/F – 14/F	Workshop	3.5	2 hours	0.5
1/F	E/M	2.5	2 hours	0.3
1/F	Workshop	3.5	2 hours	0.5
G/F	Loading/Unloading	4.5	1 hour	0
B/F	Car park	2.5	4 hours	0.5

\* The minimum clear headroom is the floor height clear of all structures, finishes and building services.

3. The restrictions on the location of vertical structural elements are as follows:

Floor Mark	Area	Restrictions
1/F – 14/F	Workshop	- Minimum spacing of internal columns is 9.0m centres.
1/F	E/M	- Minimum spacing of internal columns is 9.0m centres.
G/F	Driveway	- Not permitted inside the driveway and access ramp.
G/F	Loading/Unloading	- Minimum spacing of internal columns is 9.0m centres.
B/F	Car Parking	- Minimum spacing of internal columns is 6.0m centres.

4. The main roof structure above tower and flat roof structure at 2/F shall not be inverted.

### **Imposed Loads**

5. The imposed loads shall be in accordance with the latest version of the Hong Kong Code of Practice for Dead and Imposed Loads.
6. The imposed load for workshop shall be Class 5 according to table 3.2 of the Code of Practice for Dead and Imposed Loads. Specific use shall be offices for storage and normal filing purposes.

### **Wind Loads**

7. The wind loads shall be in accordance with the Code of Practice on Wind Effects in Hong Kong 2004.

### **Site Conditions**

8. Abutting the eastern boundary of the site is a 5-storey reinforced concrete building with shallow footing foundation.
9. Ground conditions:

From +6mPD to -4mPD :	Loose Fill with SPT N-value < 10
From -4mPD to -8mPD :	Medium dense sand with SPT N-value 10-50
Below -8mPD :	Slightly to moderately decomposed moderately strong rock of material weathering grade III or better, with total core recovery of more than 85% of the grade.
10. The highest possible groundwater level is at +6.0 mPD.

### **Omit from Consideration**

11. Detailed layout and design of the structure inside the service core.

## Section A

- a. Prepare a design appraisal with appropriate sketches including two distinct and viable solutions for the proposed industrial building including two viable foundation schemes. Indicate clearly the functional framing, load transfer and stability aspects of each scheme to meet all client's requirements. Identify the solution you recommend and give reasons for your choice.

**(30 marks)**

- b. Explain how the structure will resist wind load including detailed description of the structural wind loads and design assumption. Prepare a detailed wind load calculation and stability checking for the proposed industrial building.

**(10 marks)**

## Section B

For the solution recommended in Section A:

- c. Prepare design calculations to establish the form and size of all principal structural elements for superstructure from G/F to 2/F, including transfer and corbel structures.

**(14 marks)**

- d. Prepare dimensional framing plans for G/F to typical floor including transfer and corbel structures.

**(20 marks)**

- e. Prepare structural details for the principal structural elements from G/F to 2/F, including transfer structures, for cost estimation purpose.

**(14 marks)**

- f. Prepare the design calculation for the building foundation.

**(4 marks)**

- g. Prepare a preliminary foundation layout plan.

**(4 marks)**

- h. Prepare an outline construction program covering essential activities from commencement of foundation to completion of structural works.

**(4 marks)**

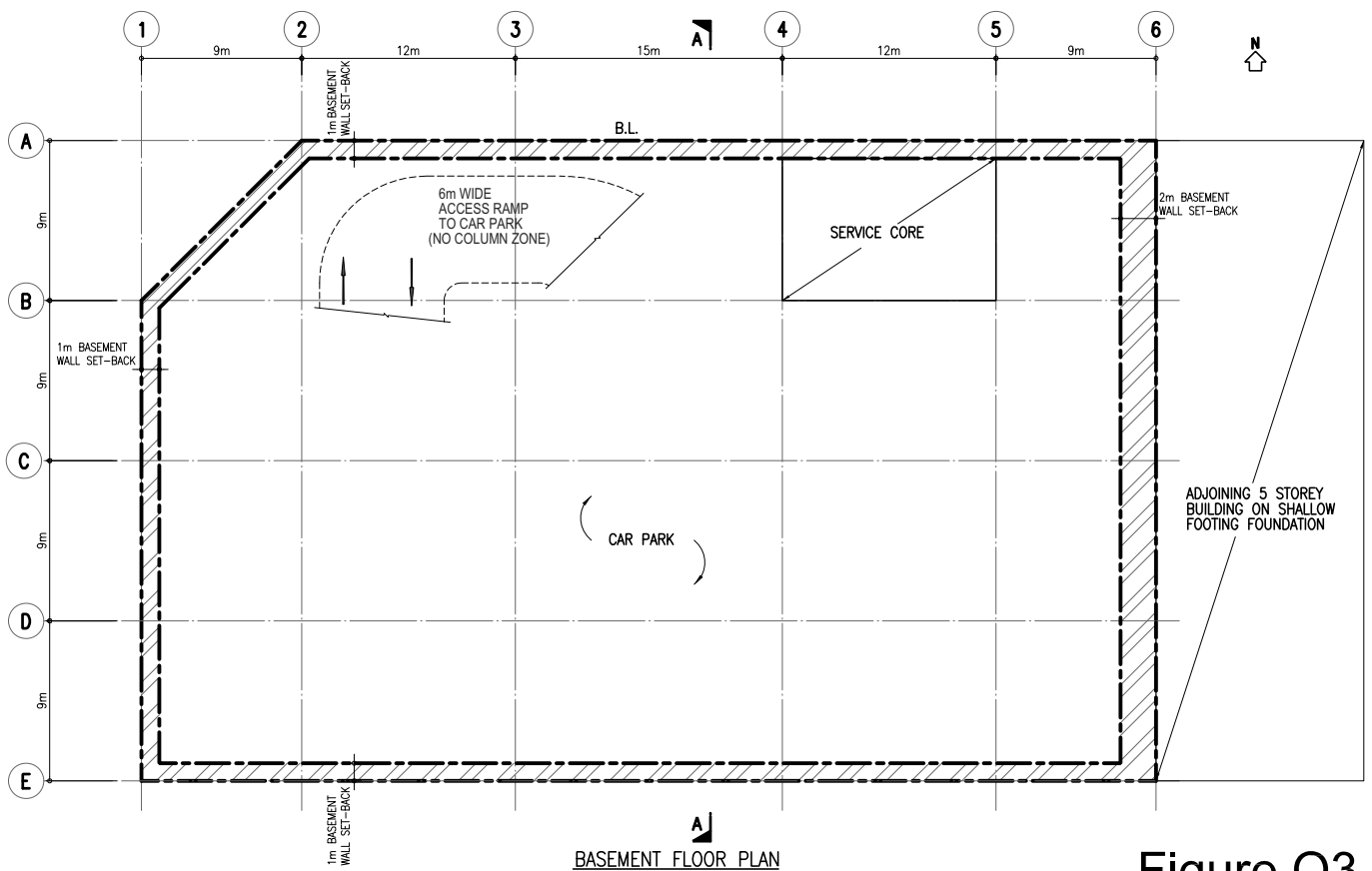
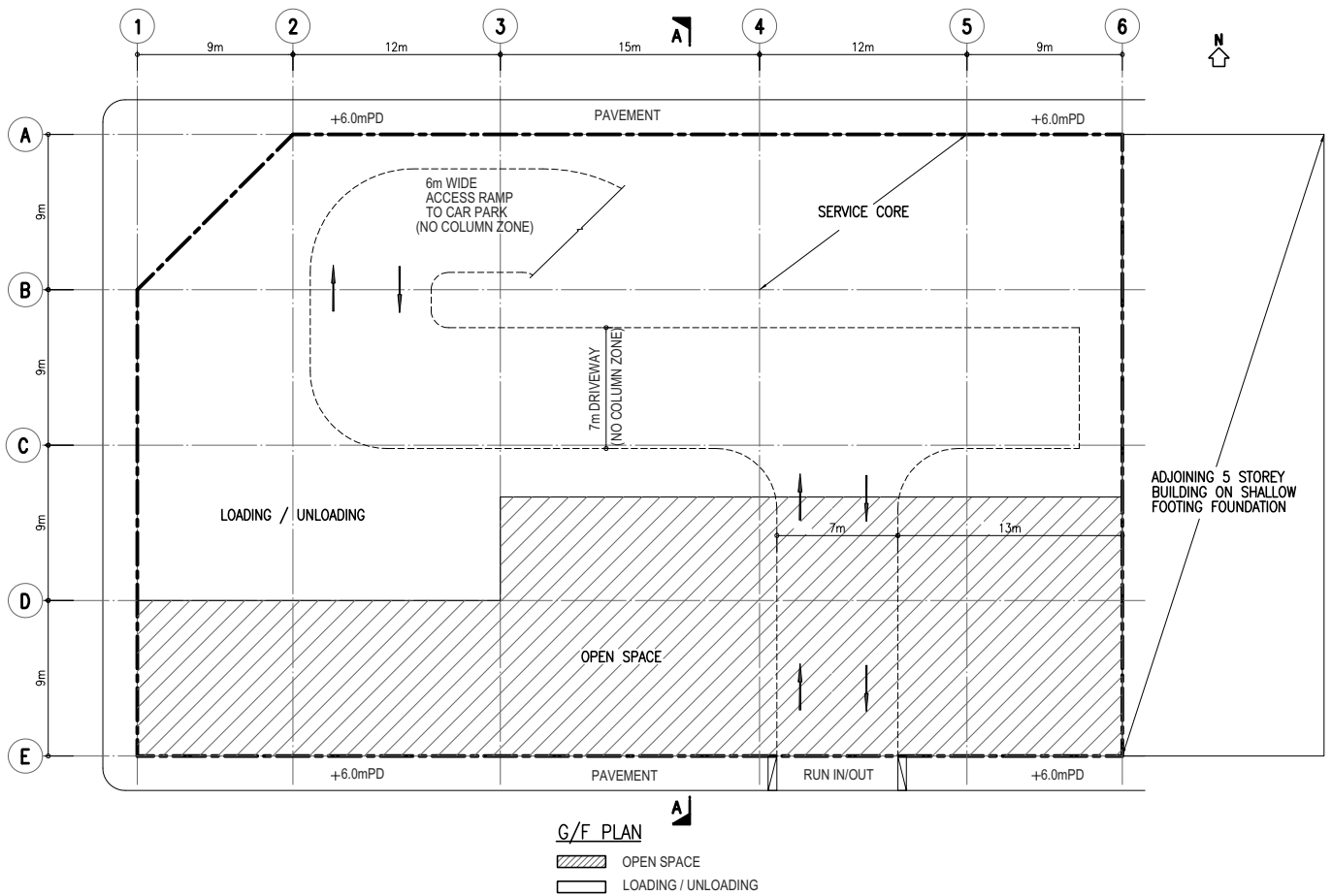

Figure Q3

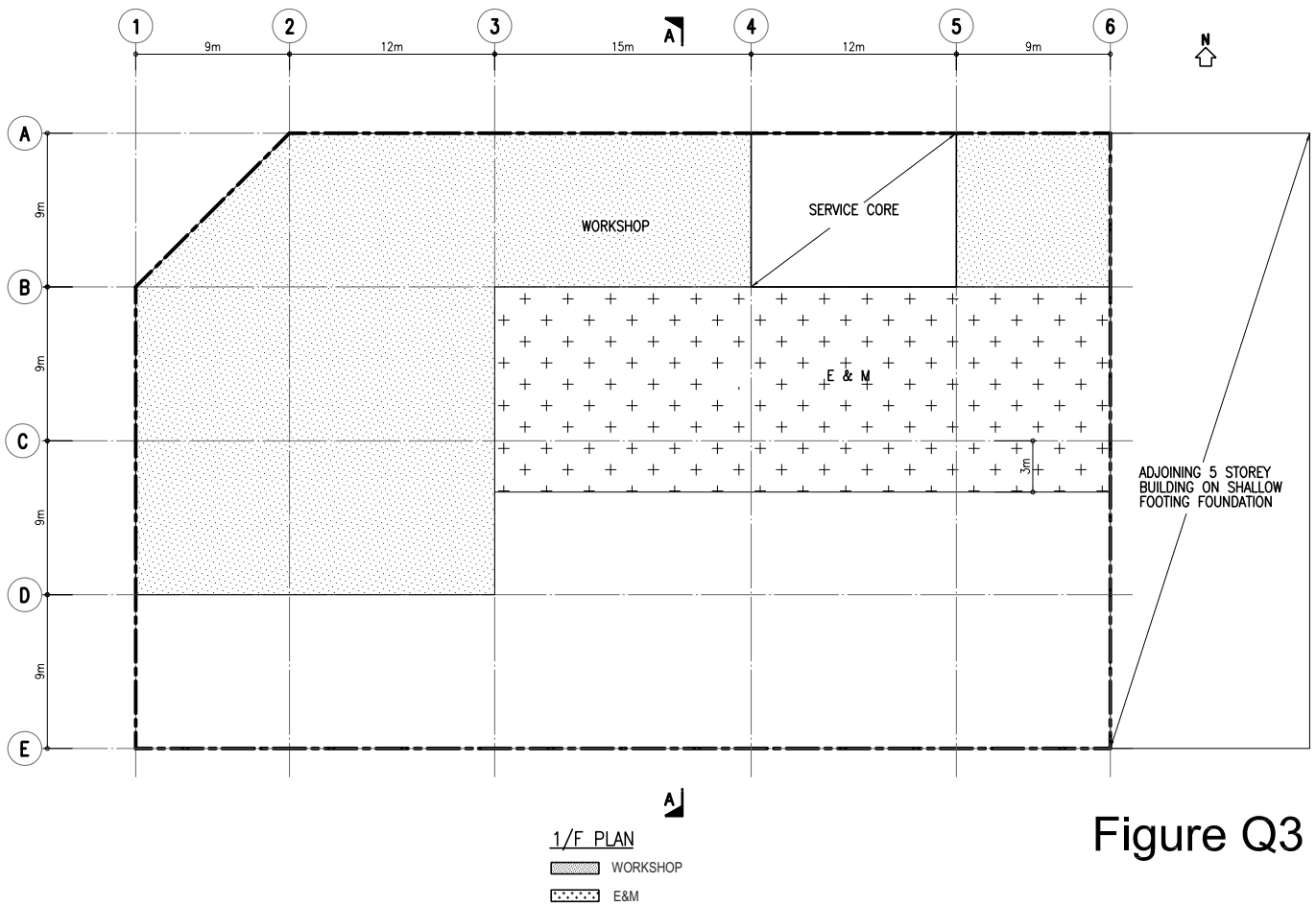
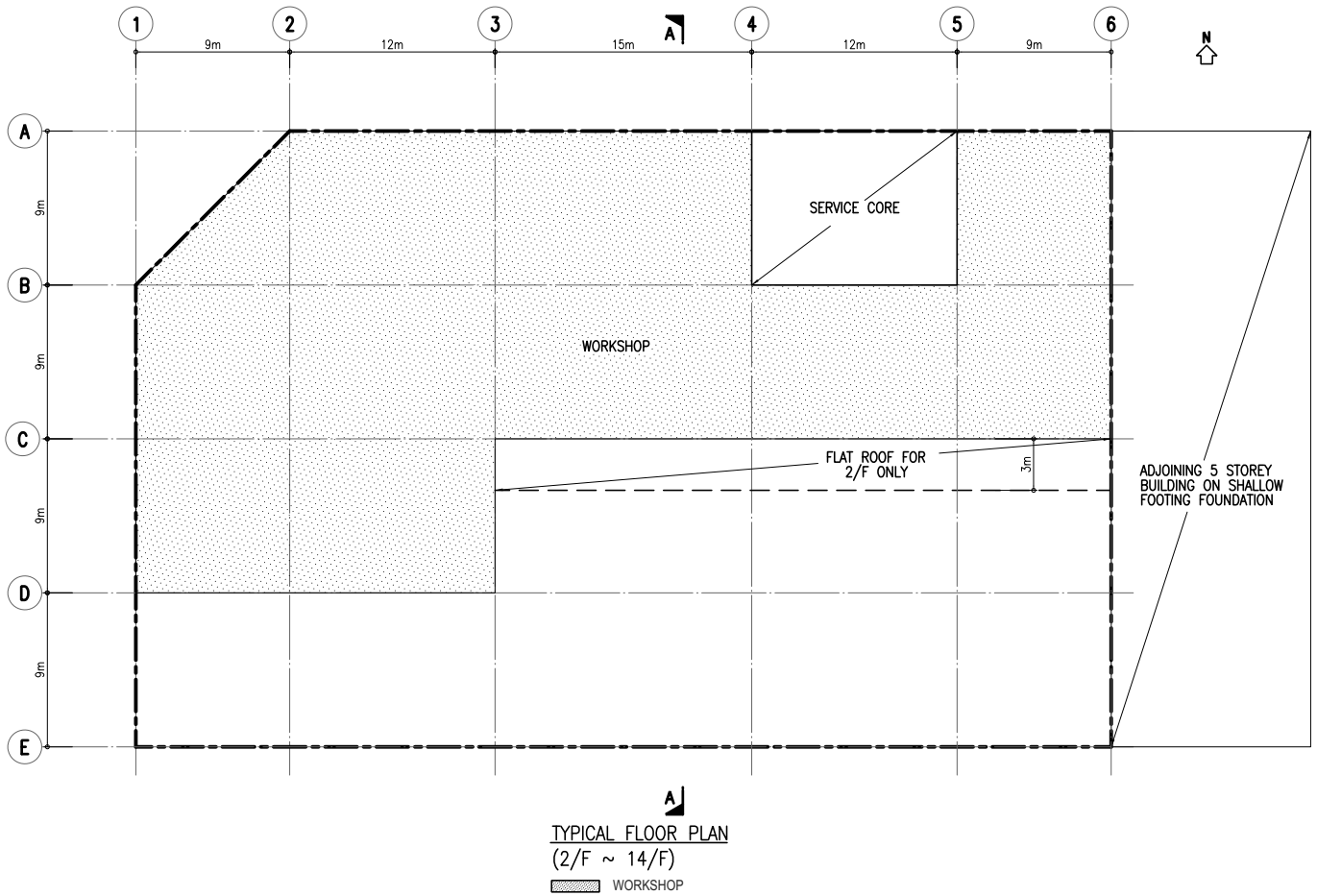
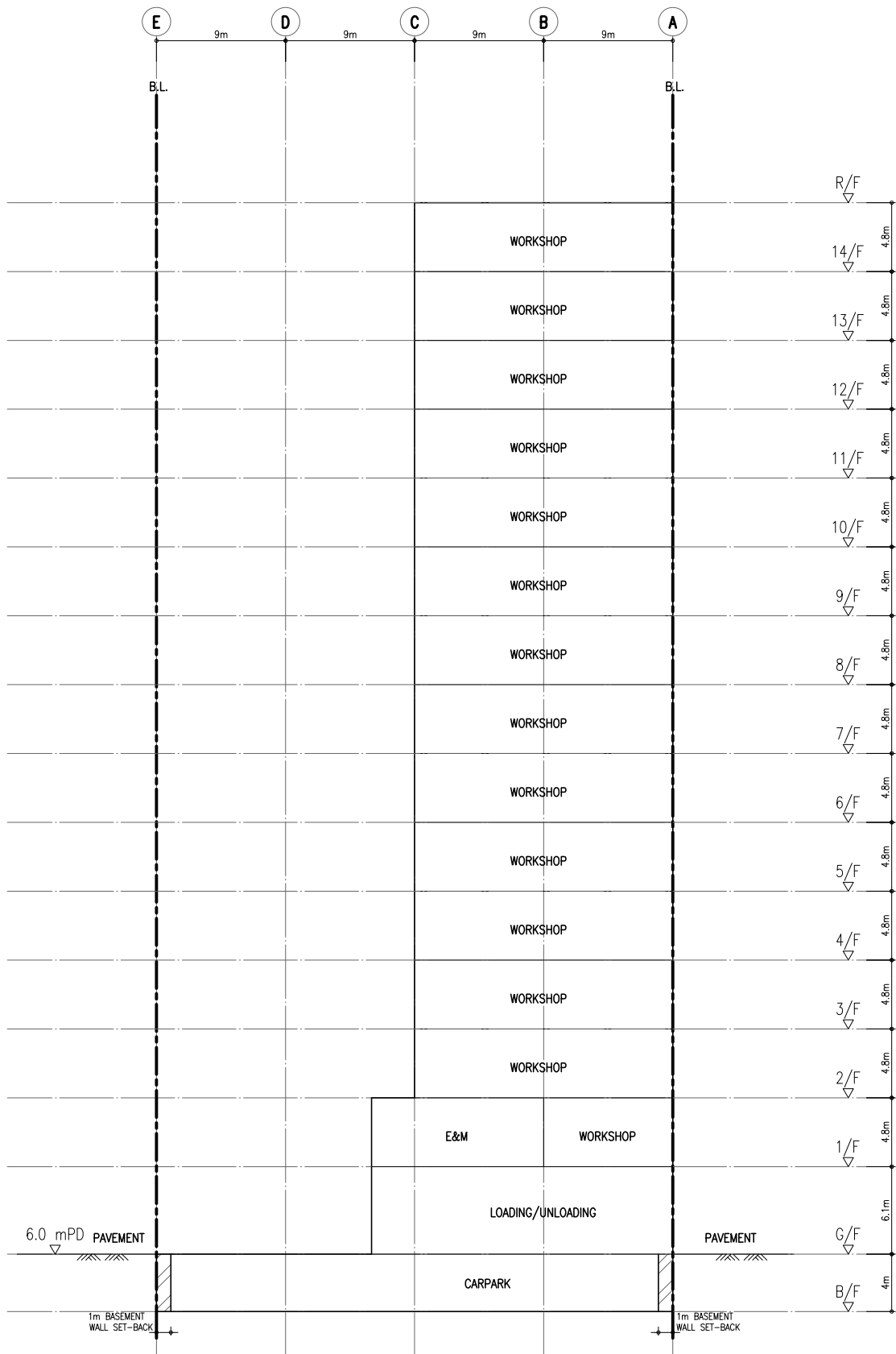

Figure Q3



SECTION A - A

Figure Q3

## Question 4      Workshop Craneage

### Client's Requirements

The following client's requirements must be met:

1. A newly acquired seashore site of 108.0m by 25.0m has been leveled and is to be used for a single storey workshop with lifting facility. The lifting facility, in addition to servicing full coverage of the workshop area, is also to be used for the offloading of materials from barges tied up to the seawall. This involves a reach of 5.0m beyond the seawall. See figure Q4.
2. Covering to the roof and cladding to the elevations of the workshop shall be of light weight material. The workshop is to be column free, except perimeter columns.
3. The supporting structure to the workshop and the crane must be on the land side of the seawall. No columns are permitted in the sea. The maximum spacing of perimeter columns in the workshop is to be 9.0m. The maximum overall height of the workshop is to be limited to 14.0m.
4. The lifting crane is to be electrically operated for both lifting and traveling. It has a safe working load of 150 kN. The minimum hook approach is to be 1.3m. The overall depth of the crane including the hoist is to be 1.5m with a clear height of 8.0m from floor level to the underside of the crane bridge.
5. A door of 10.0m wide x 8.0m high is to be provided in the south elevation of the workshop.

### Imposed Loads

6. Roof	0.75 kN/m <sup>2</sup>
Workshop floor	50.0 kN/m <sup>2</sup>
Crane weight	180 kN
Hoist unit	20 kN

## **Wind Loads**

7. The wind loads shall be in accordance with the Code of Practice on Wind Effects in Hong Kong 2004.

## **Site Conditions**

8. The site is in Lantau Island.
9. Ground conditions are:

From +5mPD to 0mPD	Loose fill with SPT N-value < 10
Below 0mPD	Moderately decomposed rock with total core recovery > 50%
10. The seawall sits on moderately decomposed rock with a base width of 3m.

## **Omit from Consideration**

11. Design of crane mechanisms and the crane rails.

## **Section A**

- a. Prepare a design appraisal with appropriate sketches indicating two distinct and viable solutions for the proposed structure, and one solution for the foundation and the craneage. Indicate clearly the functional framing, load transfer and stability aspects of the proposed structure of each scheme to meet all client's requirements. Identify the solution you recommend and give reasons for your choice.

**(40 marks)**

## **Section B**

For the solution recommended in Section A:

- b. Prepare sufficient design calculations to establish the form and size of all principal structural elements including the foundation.

**(20 marks)**

- c. Prepare framing plans, sections and elevations to show the dimensions, layouts and disposition of the structural elements and critical details for estimating purposes.

**(20 marks)**

- d. Prepare a detailed method statement covering essential activities for the safe construction of the building, showing the erection sequence on how temporary stability is maintained throughout construction of the building.

**(20 marks)**

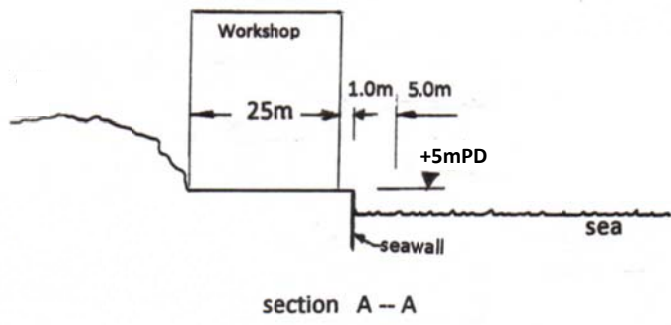
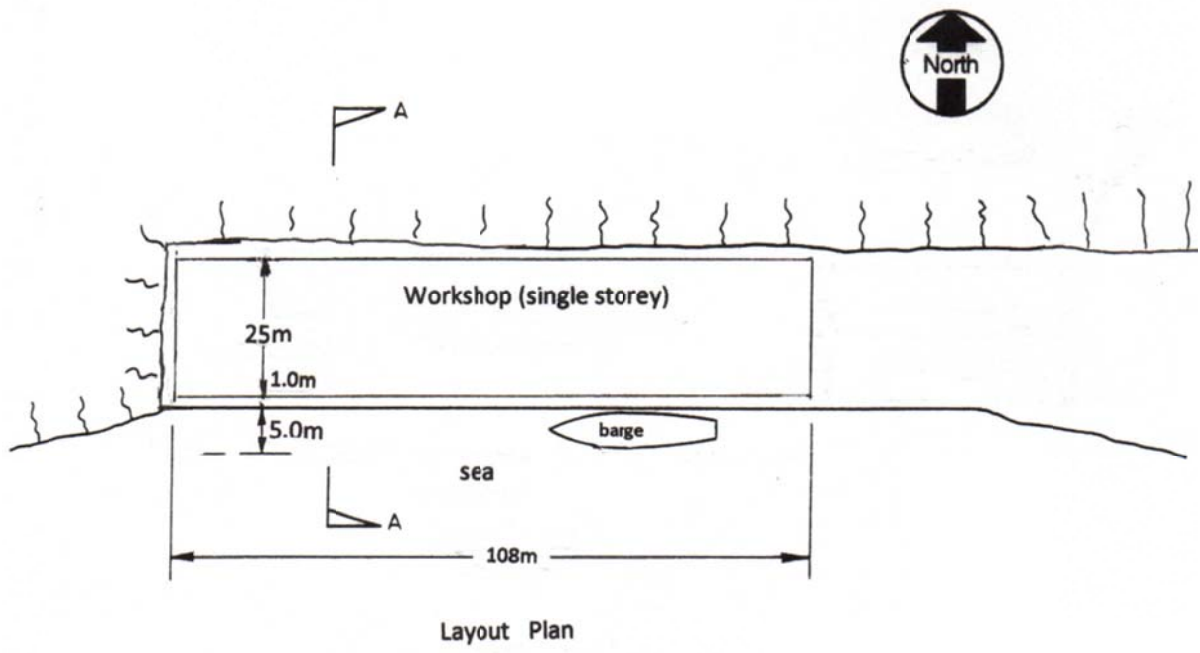

Figure Q4

## **Question 5      Road Bridge with Observation Platforms over River**

### **Client's Requirements**

The following client's requirements must be met:

1. A new bridge carrying a dual two-lane carriageway with footpath and observation platforms at both sides is to be constructed over a river in rural area as shown in Figure Q5.
2. Navigation envelopes of 15.0m x 4.5m and 10.0m x 4.0m respectively have to be maintained at all time as shown in Figure Q5.
3. For navigation purpose, supporting column(s), if required inside the river, are only permitted within the column zone as shown in Figure Q5. Temporary works are not allowed within the navigation envelopes but permitted within the flooding zones.
4. The river traffic must remain in operation at all times except from 1:00am to 5:00am for a period of not more than 6 months by special application to the relevant authorities to facilitate bridge construction. Bridge deck and parapet construction work may only be carried out above the navigation envelopes during their closure periods.
5. The longitudinal gradient of the bridge deck shall not be steeper than 1:100. A later clearance of 5.0m must be provided between the bridge abutment wall and the river bank.
6. Two observation platforms are attached to the footpath for the pedestrian to enjoy the natural beauty of the river side.

### **Design Requirements**

7. The structural design shall be in accordance with the latest version of the Structures Design Manual for Highways and Railways published by the Highways Department of the HKSAR Government.

### **Imposed Loads**

- |                           |   |
|---------------------------|---|
| 8. Vertical traffic loads | UDL = 10.0 kN/m <sup>2</sup><br>Invariable KEL = 120 kN per traffic lane                  |
| Horizontal traffic loads  | 1500 kN, applied parallel to the carriageways<br>across the full width of the bridge deck |
| Footpath load             | 5.0 kN/m <sup>2</sup>   |

### **Site Conditions**

9. Ground conditions as revealed by boreholes are:
- |                     |   |
|---------------------|---|
| Ground level – 0.8m | Made up ground  |
| 0.8m – 12.0m        | Soft clay with undrained shear strength, $C_u = 40.0 \text{ kN/m}^2$                    |
| Below 15.0m         | Moderately decomposed rock with allowable bearing<br>pressure = 3,000 kN/m <sup>2</sup> |
- Ground water is encountered at 1.8m below ground level.

### **Omit from Consideration**

10. Design calculations for bridge parapet and bridge abutment retaining walls.

## **Section A**

- a. Prepare a design appraisal with appropriate sketches indicating two distinct and viable solutions for the proposed bridge structure. Indicate clearly the functional framing, load transfer, safety and stability aspects of each scheme to meet all client's requirements. Identify the solution you recommend and give reasons for your choice.

**(40 marks)**

## **Section B**

For the solution recommended in Section A:

- b. Prepare sufficient design calculations to establish the form and size of all the principal structural elements including the foundation.

**(20 marks)**

- c. Prepare framing plans, sections and elevations to show the dimensions, layout and disposition of the structural elements and critical details of the bridge structure for estimating purposes.

**(20 marks)**

- d. Prepare a detailed method statement covering essential activities for the safe construction of the bridge including foundation works.

**(10 marks)**

- e. Prepare a detailed construction program covering essential activities from commencement of foundation to completion of structural works.

**(10 marks)**

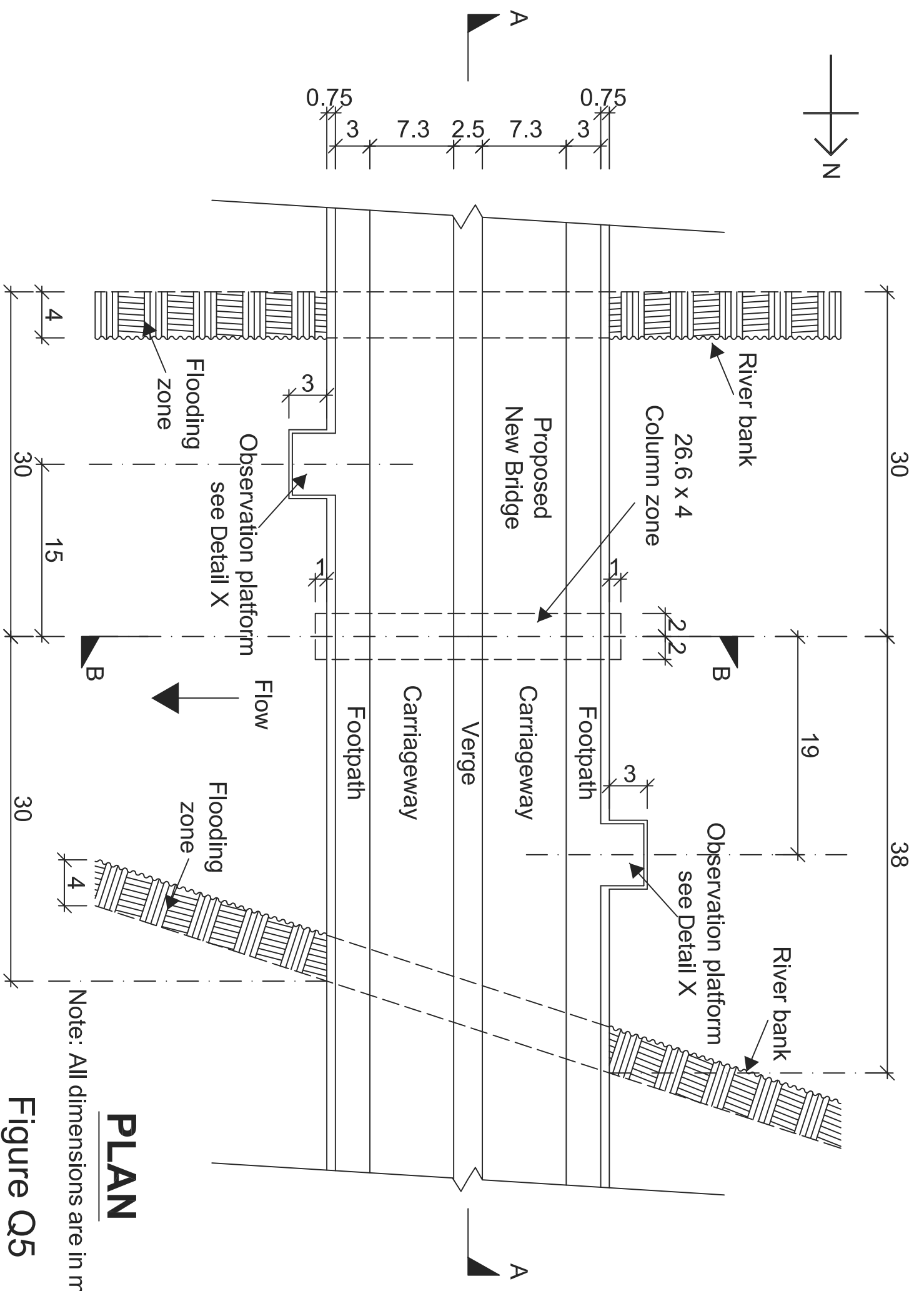

**PLAN**

Note: All dimensions are in metres

Figure Q5

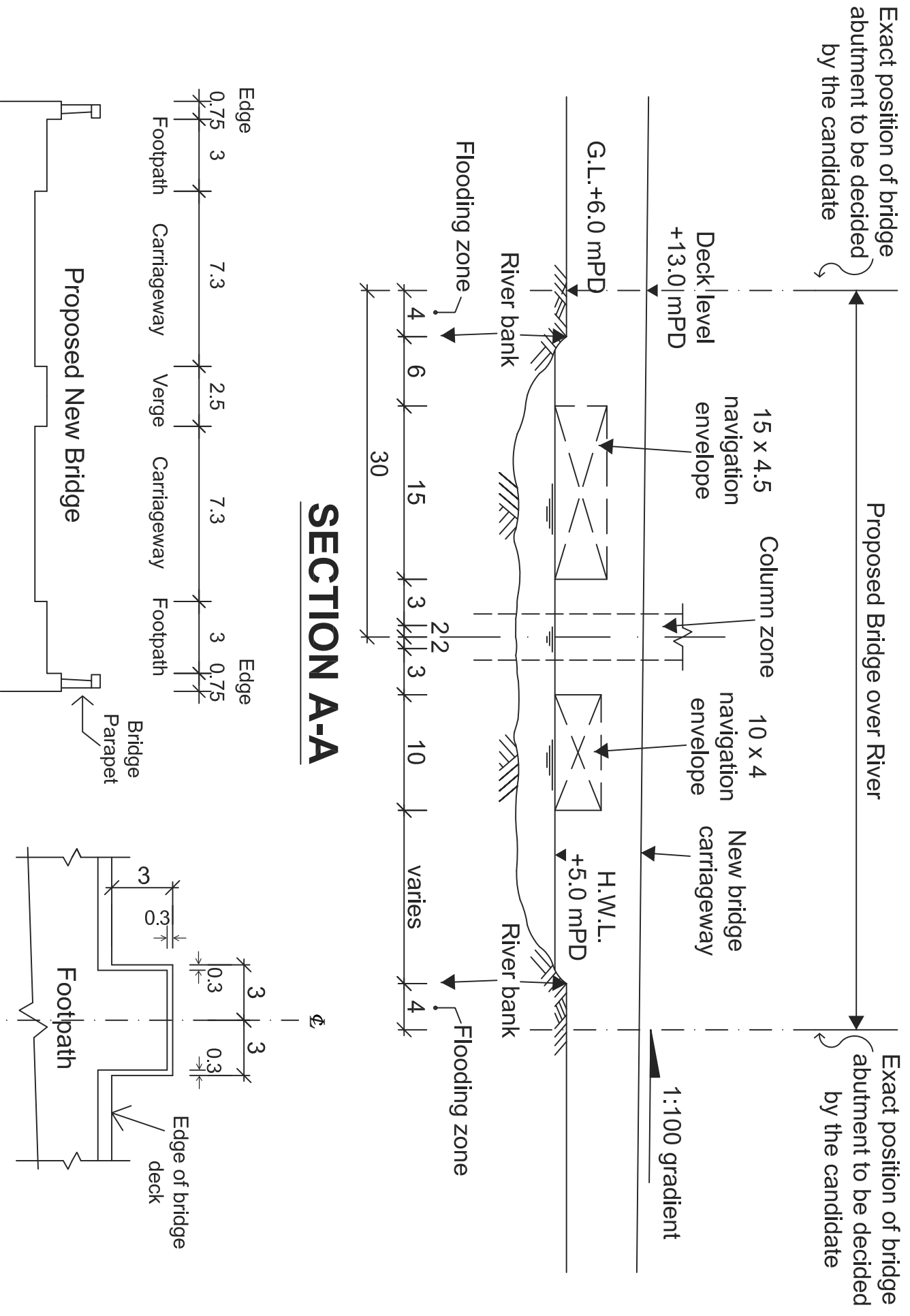

**SECTION A-A**

**SECTION B-B**

**Detail X**

(Observation Platform)

Note: All dimensions are in metres

Figure Q5